

9040 CASCADE LOW VOLTAGE CONTROL UNIT FOR THE REA / REM™ CASCADE COATING SYSTEMS

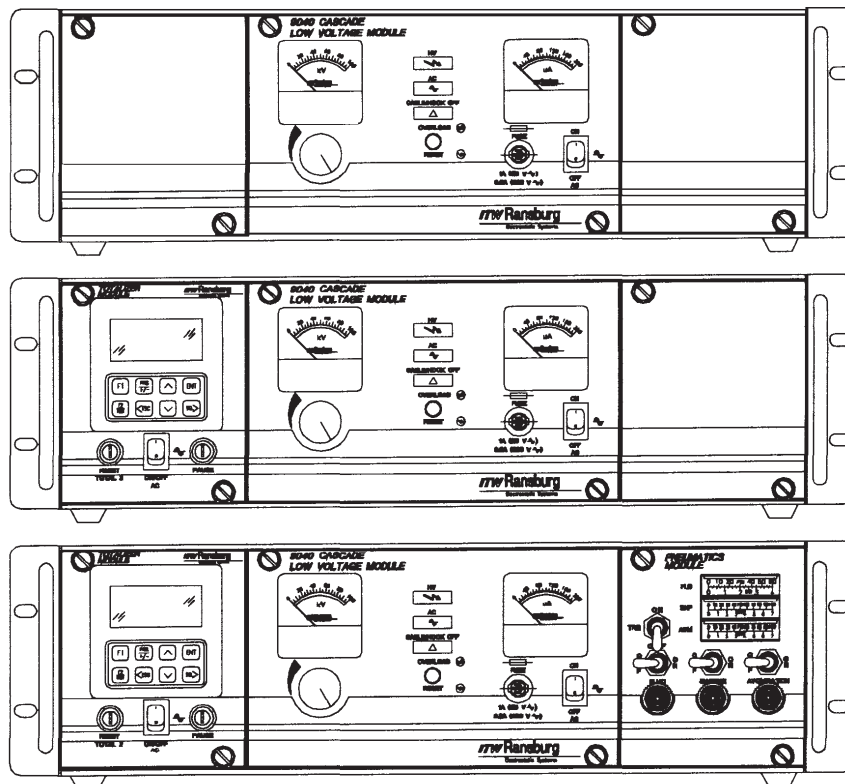

MODELS:

- 76580-1XXXX REA-70 APPLICATOR
- 76580-4XXXX REM AUTOMATIC
- 76580-5XXXX REA9000 AUTOMATIC
- 76580-6XXXX REA-90 WATERBORNE APPLICATOR
- 76580-7XXXX REA-90 SOLVENTBORNE APPLICATOR
- 76580-8XXXX REA-90 SOLVENTBORNE AUTOMATIC
- 76580-9XXXX REA-90 WATERBORNE AUTOMATIC

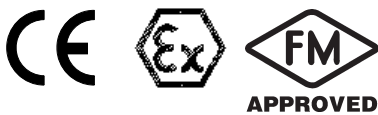

IMPORTANT: Before using this equipment, carefully read **SAFETY PRECAUTIONS**, starting on page 1, and all instructions in this manual. Keep this Service Manual for future reference.

Service Manual Price: €25.00 (Euro)
\$30.00 (U.S.)

NOTE: This manual has been changed from **CP-97-04.2** to revision **CP-97-04.3**. Reasons for this change are noted under “Manual Change Summary” inside the back cover of this manual.

CONTENTS

	PAGE
SAFETY:	1-4
SAFETY PRECAUTIONS.....	1
HAZARDS/SAFEGUARDS.....	2-4
ATEX	5-6
EUROPEAN ATEX DIRECTIVE.....	5
EUROPEAN ATEX LABELS.....	6
INTRODUCTION:	7-10
DESCRIPTION.....	7-9
SPECIFICATIONS.....	9
9040 CASCADE CONTROL UNIT FEATURES	10
INSTALLATION:	11-20
LOCATION.....	11
INPUT CONNECTIONS.....	11-12
EXTERNAL CONNECTIONS.....	13-18
COMBINATION TRIPLE SETPOINT / ANALOG INPUT BOARD LAYOUT.....	19
TYPICAL REA / REM APPLICATOR INSTALLATION.....	19-20
OPERATION:	21-24
OPERATOR CONTROLS.....	21
OPERATING PROCEDURES.....	22-23
MAINTENANCE:	25-36
ROUTINE PREVENTIVE MAINTENANCE.....	25
TROUBLESHOOTING.....	25-28
TROUBLESHOOTING FLOW CHARTS.....	29-30
TROUBLESHOOTING DIAGRAM.....	30
9040 CASCADE CONTROL UNIT BLOCK DIAGRAM.....	31
SERVICE LEVEL.....	32
REPLACEMENT PROCEDURES.....	32-35
PARTS IDENTIFICATION:	37-40
9040 CASCADE LOW VOLTAGE CONTROL UNIT PARTS DIAGRAM / PARTS LIST.....	37-39
RECOMMENDED SPARE PARTS.....	40
WARRANTY POLICIES:	41
LIMITED WARRANTY.....	41

SAFETY

SAFETY PRECAUTIONS

Before operating, maintaining or servicing any ITW Ransburg electrostatic coating system, read and understand all of the technical and safety literature for your ITW Ransburg products. This manual contains information that is important for you to know and understand. This information relates to **USER SAFETY** and **PREVENTING EQUIPMENT PROBLEMS**. To help you recognize this information, we use the following symbols. Please pay particular attention to these sections.

A WARNING! states information to alert you to a situation that might cause serious injury if instructions are not followed.

A CAUTION! states information that tells how to prevent damage to equipment or how to avoid a situation that might cause minor injury.

A NOTE is information relevant to the procedure in progress.

While this manual lists standard specifications and service procedures, some minor deviations may be found between this literature and your equipment. Differences in local codes and plant requirements, material delivery requirements, etc., make such variations inevitable. Compare this manual with your system installation drawings and appropriate ITW Ransburg equipment manuals to reconcile such differences.

Careful study and continued use of this manual will provide a better understanding of the equipment and process, resulting in more efficient operation, longer trouble-free service and faster, easier troubleshooting. If you do not have the manuals and safety literature for your Ransburg system, contact your local ITW Ransburg representative or ITW Ransburg.

WARNING



► The user **MUST** read and be familiar with the Safety Section in this manual and the ITW Ransburg safety literature therein identified.

► This manual **MUST** be read and thoroughly understood by **ALL** personnel who operate, clean or maintain this equipment! Special care should be taken to ensure that the **WARNINGS** and safety requirements for operating and servicing the equipment are followed. The user should be aware of and adhere to **ALL** local building and fire codes and ordinances as well as **NFPA-33 SAFETY STANDARD**, prior to installing, operating, and/or servicing this equipment.

WARNING

► The hazards shown on the following page may occur during the normal use of this equipment. Please read the hazard chart beginning on page 2.

AREA Tells where hazards may occur.	HAZARD Tells what the hazard is.	SAFEGUARDS Tells how to avoid the hazard.
<p>Spray Area</p> 	<p>Fire Hazard</p> <p>Improper or inadequate operation and maintenance procedures will cause a fire hazard.</p> <p>Protection against inadvertent arcing that is capable of causing fire or explosion is lost if any safety interlocks are disabled during operation. Frequent power supply shutdown indicates a problem in the system requiring correction.</p>	<p>Fire extinguishing equipment must be present in the spray area and tested periodically.</p> <p>Spray areas must be kept clean to prevent the accumulation of combustible residues.</p> <p>Smoking must never be allowed in the spray area.</p> <p>The high voltage supplied to the atomizer must be turned off prior to cleaning, flushing or maintenance.</p> <p>When using solvents for cleaning:</p> <p>Those used for equipment flushing should have flash points equal to or higher than those of the coating material.</p> <p>Those used for general cleaning must have flash points above 100°F (37.8°C).</p> <p>Spray booth ventilation must be kept at the rates required by NFPA-33, OSHA, and local codes. In addition, ventilation must be maintained during cleaning operations using flammable or combustible solvents.</p> <p>Electrostatic arcing must be prevented.</p> <p>Test only in areas free of combustible material.</p> <p>Testing may require high voltage to be on, but only as instructed.</p> <p>Non-factory replacement parts or unauthorized equipment modifications may cause fire or injury.</p> <p>If used, the key switch bypass is intended for use only during set-up operations. Production should never be done with safety interlocks disabled.</p> <p>Never use equipment intended for use in waterborne installations to spray solvent based materials.</p> <p>The paint process and equipment should be set up and operated in accordance with NFPA-33, NEC, and OSHA requirements.</p>

AREA Tells where hazards may occur.	HAZARD Tells what the hazard is.	SAFEGUARDS Tells how to avoid the hazard.
<p>General Use and Maintenance</p> 	<p>Improper operation or maintenance may create a hazard.</p> <p>Personnel must be properly trained in the use of this equipment.</p>	<p>Personnel must be given training in accordance with the requirements of NFPA-33.</p> <p>Instructions and safety precautions must be read and understood prior to using this equipment.</p> <p>Comply with appropriate local, state, and national codes governing ventilation, fire protection, operation maintenance, and housekeeping. Reference OSHA, NFPA-33, and your insurance company requirements.</p>
<p>Electrical Equipment</p> 	<p>High voltage equipment is utilized. Arcing in areas of flammable or combustible materials may occur. Personnel are exposed to high voltage during operation and maintenance.</p> <p>Protection against inadvertent arcing that may cause a fire or explosion is lost if safety circuits are disabled during operation.</p> <p>Frequent power supply shutdown indicates a problem in the system which requires correction.</p> <p>An electrical arc can ignite coating materials and cause a fire or explosion.</p>	<p>The power supply, optional remote control cabinet, and all other electrical equipment must be located outside Class I or II, Division 1 and 2 hazardous areas. Refer to NFPA-33.</p> <p>Turn the power supply OFF before working on the equipment.</p> <p>Test only in areas free of flammable or combustible material.</p> <p>Testing may require high voltage to be on, but only as instructed.</p> <p>Production should never be done with the safety circuits disabled.</p> <p>Before turning the high voltage on, make sure no objects are within the sparking distance.</p>

AREA Tells where hazards may occur.	HAZARD Tells what the hazard is.	SAFEGUARDS Tells how to avoid the hazard.
<p>Spray Area / High Voltage Equipment</p> 	<p>This is a high voltage device that can produce electrical arcs capable of igniting coating materials.</p>	<p>Parts being sprayed must be supported on conveyors or hangers and be grounded. The resistance between the part and ground must not exceed 1 megohm. (Reference NFPA-33.)</p> <p>A safe distance must be maintained between the parts being coated and the atomizer bell. A distance of at least 1 inch for each 10 KV of power supply output voltage is required at all times.</p> <p>Parts must be supported so that they will not swing and reduce the clearance specified above.</p> <p>All electrically conductive objects in the spray area, with the exception of those objects required by the process to be at high voltage, must be grounded.</p> <p>Unless specifically approved for use in hazardous locations, the power supply and other electrical equipment must not be used in Class I, Division 1 or 2 locations.</p>

EUROPEAN ATEX DIRECTIVE 94/9/EC, ANNEX II, 1.0.6

The following instructions apply to equipment covered by certificate number Sira 08ATEX5040X:

1. The equipment may be used with flammable gases and vapors with apparatus groups II and with temperature class T6.
2. The equipment is only certified for use in ambient temperatures in the range +12.8°C to +40°C and should not be used outside this range.
3. Installation shall be carried out by suitably trained personnel in accordance with the applicable code of practice e.g. EN 60079-14:1997.
4. Inspection and maintenance of this equipment shall be carried out by suitably trained personnel in accordance with the applicable code of practice e.g. EN 60079-17.
5. Repair of this equipment shall be carried out by suitable trained personnel in accordance with the applicable code of practice e.g. EN 60079-19.
6. Putting into service, use, assembling, and adjustment of the equipment shall be fitted by suitably trained personnel in accordance with the manufacturer's documentation.

Refer to the "Table of Contents" of this service manual:

- a. Installation
- b. Operation
- c. Maintenance
- d. Parts Identification

7. Components to be incorporated into or used as replacement parts of the equipment shall be fitted by suitably trained personnel in accordance with the manufacturer's documentation.

8. The certification of this equipment relies upon the following materials used in its construction:

If the equipment is likely to come into contact with aggressive substances, then it is the responsibility of the user to take suitable precautions that prevent it from being adversely affected, thus ensuring that the type of protection provided by the equipment is not compromised.

Aggressive substances: e.g. acidic liquids or gases that may attack metals, or solvents that may affect polymeric materials.

Suitable precautions: e.g. regular checks as part of routine inspections or establishing from the material's data sheets that it is resistant to specific chemicals.

Refer to "Specifications" in the "Introduction" section:

- a. All fluid passages contain stainless steel or nylon fittings.
- b. High voltage cascade is encapsulated with a solvent resistant epoxy.

9. A recapitulation of the certification marking is detailed in the "Atex" section, on the next page, drawing numbers: 72562 and 79318.

10. The characteristics of the equipment shall be detailed e.g. electrical, pressure, and voltage parameters.

The manufacturer should note that, on being put into service, the equipment must be accompanied by a translation of the instructions in the language or languages of the country in which the equipment is to be used and by the instructions in the original language.

9040 Cascade Low Voltage Control Unit ATEX Product Marking Definitions

Ex Certificate Number: Sira 08ATEX5040X

Sira = Notified Body performing EC-type examination

08 = Year of certification

ATEX = Reference to ATEX Directive

5 = Protection Concept Code (code 5 is titled Encapsulation)

040 = Document serial number

X = Special conditions for safe use apply

Product Marking



Ex = Specific marking of explosive protection
 II = Equipment Group hazardous area characteristics
 2 = Equipment Category
 G = Type of explosive atmosphere (gases, vapors, or mists)

EEx 0.24mJ = The 76580-XX 9040 Cascade Control Unit is suitable for use in electrostatic spraying installations complying with EN 50176 as they are a Type A class with a discharge energy limit of 0.24mJ.

Label 72562

ITW Ransburg, Angola, IN, USA		CONTROL UNIT/POWER SUPPLY	
WARNING FAILURE TO OBSERVE THE FOLLOWING PRECAUTIONS MAY RESULT IN AN ELECTRICAL DISCHARGE CAPABLE OF STARTING A FIRE.		PART No. 115/220	SERIAL No. "C"
1. THE ARTICLE BEING COATED MUST BE GROUNDED.		VOLTS 115/220	"D" AMPERES
2. ALL OTHER ELECTRICALLY CONDUCTING OBJECTS WITHIN ABOUT TEN FEET OF THE OPERATING SPRAY GUN MUST BE GROUNDED.		HERTZ 50/60	"E" WATTS
3. THIS CONTROL UNIT/POWER SUPPLY MUST BE INTERLOCKED WITH THE SPRAY BOOTH VENTILATORS SO AS TO PREVENT OPERATION OF THE POWER SUPPLY UNLESS VENTILATING FANS ARE IN OPERATION.		OUTPUT VOLTAGE "F"	"G" OUTPUT CURRENT
4. SERVICE WARNING - ENCLOSURE PROTECTS AGAINST SHOCK AND INJURY. SERVICE TRAINING REQUIRED.		GUN MODEL "A" "B"	MAX PAINT PRESS
5. KEEP POWER SUPPLY OUTSIDE THE HAZARDOUS AREA.		MAX APPRD 100 FT	MAX AIR PRESS
6. DO NOT ATTEMPT OPERATION OR REPAIR BEFORE READING SERVICE MANUAL.		FLOW SWITCH	
7. FOR ELECTROSTATIC PAINT FINISHING APPLICATIONS.		MAX AIR PRESS 100 PSI	FLOW PRESS 25 CFM @ 20 PSI
FM APPROVED CE 0518 Ex II (2)G EN 50050 SIRA 08ATEX5040X		LABEL REMOVAL VOIDS WARRANTY	

Label 79318



INTRODUCTION

DESCRIPTION

The ITW Ransburg REA Process

The **REA Process** is an air atomized method for applying coatings to objects electrostatically. The REA system applies a high voltage DC charge to the applicator nozzle electrode, creating an electrostatic field between the atomizer and the target object. The target is electrically grounded through its support that may be either stationary or moving.

A regulated pressure fluid system delivers coating material to the atomizer. At the atomizer, air is applied that atomizes the coating material forming a spray mist that, under the influence of the electrostatic field, becomes electrically charged. The charged particles are attracted to, and deposited on, the target object. The forces between the charged particles and the grounded target are sufficient to turn most normal overspray around and deposit it on the side and back surfaces of the target. Therefore, a high percentage of the spray is deposited on the target.

The ITW Ransburg REM Process

This is a combined air-airless atomization method for electrostatically applying coatings to objects. The **REM System** applies a high voltage DC charge to the applicator nozzle electrode, creating an electrostatic field between the atomizer and the target object. The target is electrically grounded through its support that may be either stationary or moving.

A regulated **high** pressure fluid system delivers coating material to the atomizer. There the coating material is atomized by passing through an orifice under pressure. The resulting spray mist then becomes electrically charged under the influence of the electrostatic field surrounding the atomizer. The charged particles are attracted to and deposited on the target object. The forces

between the charged particles and the grounded target are sufficient to turn most normal overspray around and deposit it on the side and back surfaces of the target. Thus, a high percentage of the spray is deposited on the target.

9040 Cascade Low Voltage Control Unit

The **9040 Cascade Control Unit** converts standard AC line voltage to a high frequency, low voltage signal ranging from 0 to 10 Vrms. This signal is supplied to the REA/REM applicator via the low voltage cable. At the applicator, the low voltage signal is converted to DC high voltage. The voltage/current characteristic is designed to optimize the charging process under varying load conditions, and to limit the operating current to a safe maximum value.

In addition to supplying low voltage output to the applicator, the 9040 Cascade control unit also provides controls for AC power ON/OFF, infinite high voltage adjustment, a high voltage meter, a current meter, an AC power ON indicator, a high voltage ON indicator, a cable fault indicator, and a current overload indicator and reset switch. Additionally, output terminals are provided for remote overload reset, analog current output, and high voltage control. Interlock connections for a conveyor and exhaust fan are also provided. A combination triple setpoint/analog input control board is also supplied with 9040 Cascade control units powering automatic spray applicators.

Optional 1/4 rack Totalizer and Pneumatics modules are available that will slide into the existing 9040 full rack enclosure. The Totalizer module is an open loop flow metering system that provides an easy and accurate means of monitoring fluid flow rates and totals. The pneumatics module consists of the required regulators, gage, and filters to deliver air to one or more electrostatic spray applicators. Utilizing these modules in addition to the 9040 Cascade control unit, allows for grouping of all controls

required to operate the spray applicator in one convenient location. See “Parts Identification” section of this manual for information on ordering Totalizer or Pneumatics modules.

The 9040 Cascade control unit has also been modularly designed so that two half rack 9040 chassis will fit into one full rack enclosure, in multiple applicator installations. The full rack enclosure has been designed for mounting in standard 19-inch rack mount cabinets.

The 78398-0X, 9040 Control Unit for single bell applications, includes an additional normally open pressure switch (3PS) connected between fuse 1FU and ON/OFF switch 1SW. The air input to this pressure switch is located at the rear of the control unit and is labeled 3PS. When the air

signal is removed from this input, the contacts of the pressure switch are open and AC power to the control unit is disconnected. The high voltage output from the 78837 Aerobell Control Module removes the air signal from pressure switch 3PS whenever the dump or solvent outputs are active. In this manner it is ensured that the control unit is powered OFF whenever the system is in dump or solvent mode.

The 9040 Cascade Control Unit is available for hand and automatic REA/REM Cascade spray applicators as follows:

9040 Part #	Used with Applicator Type	Applicator #
76580-AXXX	M90 Applicator	77073
76580-BXXXX	REA900A Automatic	77359
76580-1BCDE	REA-70 Applicator	72074
76580-2BCDE	REM Applicator	72364
76580-4BCDE	REM Automatic	73499
76580-5BCDE	REA9000 Robot or Automatic	76110, 75795
76580-6BCDE	REA-90 Waterborne Applicator	75786
76580-7BCDE	REA-90 Solventborne Applicator	75785
76580-8BCDE	REA-90 Solventborne Automatic	75787X-XXXX1
76580-9BCDE	REA-90 Waterborne Automatic	75787X-XXXX2
78398-0X	Aerobell 33	AER5001-XX4X1
	RPM Aerobell	RPM-5XXXX-PSX

- B - Designates domestic (1) or export (2) version
- C - Designates no (0), intrinsically safe (1), or fiber optic (2) Totalizer module
- D - Designates no (0), applicator (1), or automatic applicator (2) Pneumatics module
- E - Designates the number of Pneumatics and/or Totalizer modules desired

NOTE

▶ Except where indicated, this manual is applicable to all models of the 9040 Cascade control unit.

The 9040 Cascade control unit is available from the factory in the following versions only:

1. One control unit with no Totalizer or Pneumatics modules
2. One control unit with one Totalizer module and no Pneumatics module
3. One control unit with one Totalizer module and one Pneumatics module
4. One control unit with one Pneumatics module and no Totalizer module

For applications requiring two Totalizer or Pneumatics modules in a rack with one control unit, the required modules can be purchased separately as a kit. (See "Parts Identification" section.)

SPECIFICATIONS

Environmental / Physical

Height:	5.2-Inches
Width:	16.9-Inches (19-Inches ear to ear)
Depth:	12.1-Inches
Weight:	15 lbs.

Electrical Requirements

Input:	
Voltage:	90-264 VAC
Current:	0.4/0.2 Amps AC
Frequency:	50/60 Hertz
Wattage:	40 Watts (Maximum)
Output:	
Voltage:	0-10 V RMS
Current:	1.5 Amp RMS (Maximum)
Pneumatic Supply Air:	100 psi maximum

The 13742-01 Air Flow Switch assembly used in the following 9040 Control Units has a maximum working pressure of 100 psi:

76580-1XXXX REA 70 Applicator
 76580-6XXXX REA90 Waterborne Applicator
 76580-7XXXX REA90 Solventborne Applicator

Exceeding this pressure may cause the flow switch to burst. Ensure that the air input to the IN port of the flow switch on these units is supplied from a 100 psi or less regulated and filtered air supply.

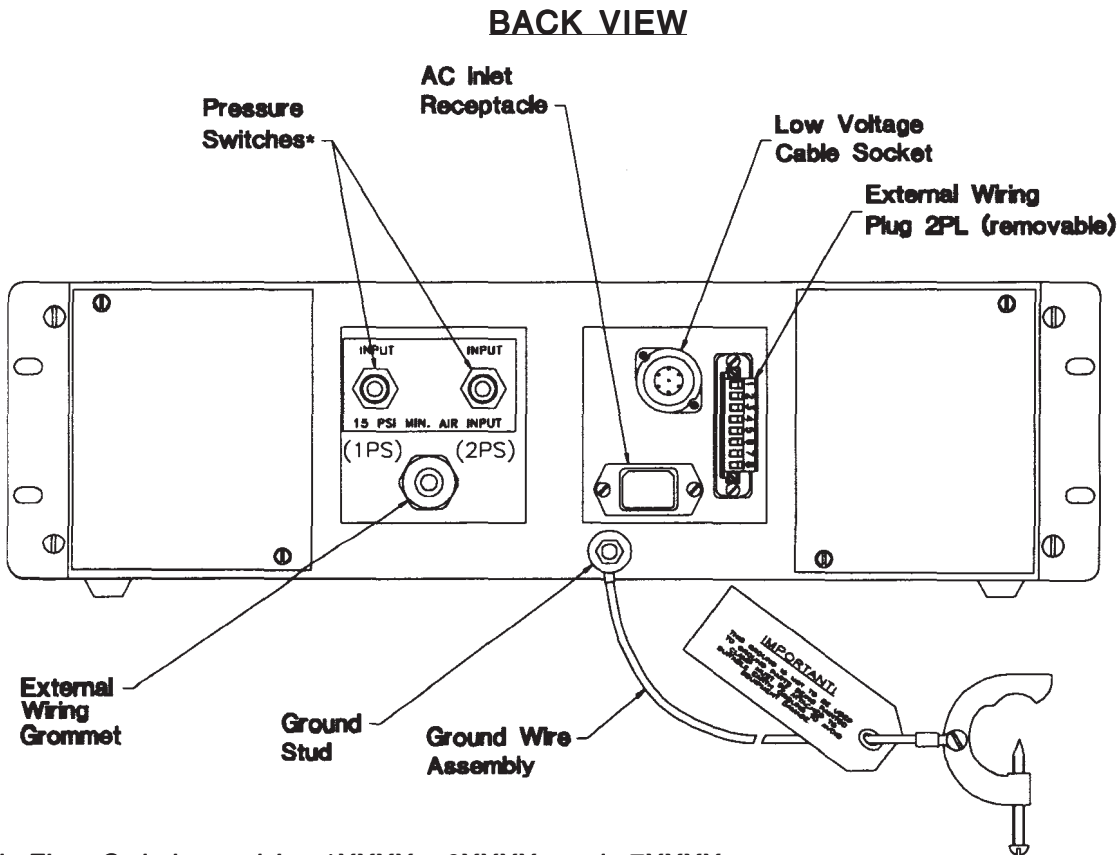
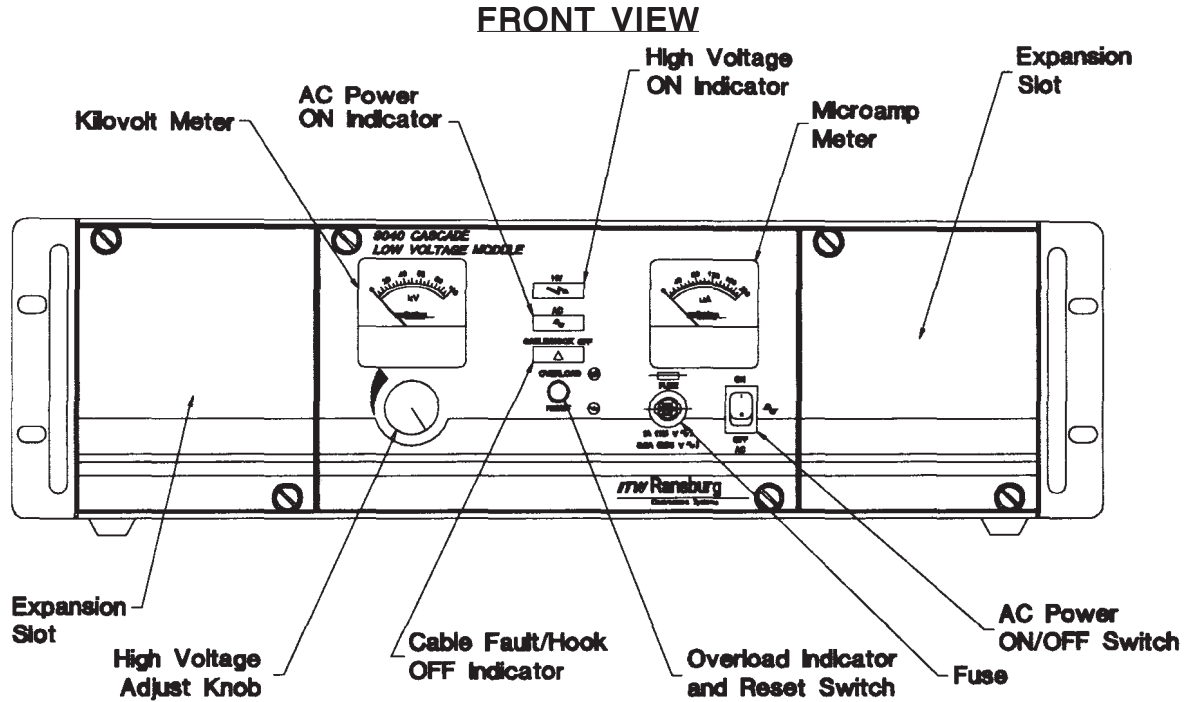

* Air Flow Switch used in -1XXXX, -6XXXX, and -7XXXX.
 Two pressure switches used in -3XXXX, -4XXXX, -5XXXX, -8XXXX, and -9XXXX.
 No pressure switch or flow switch used in -2XXXX.

Figure 1: 9040 Cascade Control Unit Features

INSTALLATION

! WARNING

- ▶ The 9040 Cascade control unit **MUST** be located outside the hazardous area. (See NFPA-33, OSHA, and ITW Ransburg Literature “Operating Your Electrostatic Coating System Safely”.)
- ▶ The user **MUST** read and be familiar with the SAFETY and SAFETY PRECAUTIONS.
- ▶ This manual **MUST** be read and thoroughly understood by ALL personnel who operate, clean, or maintain this equipment! Special care should be taken to ensure that the WARNINGS and requirements for operating and servicing safely are followed. The user should be aware of and adhere to ALL local building and fire codes and ordinances as well as NFPA-33 and OSH prior to installing, operating, and/or servicing this equipment.

NOTE

- ▶ As each installation is unique, this information is intended to provide **general** installation information for the 9040 Cascade control unit. Consult your authorized ITW Ransburg representative for **specific** directions pertaining to the installation of your equipment.

LOCATION

Install the 9040 Cascade control unit in an area outside the hazardous location, where it will be protected from the possibility of environmental intrusion, such as dust or moisture, and ambient temperatures do not exceed 120°F, but as close to the applicator as possible to minimize the length of low voltage cable. The control unit may be free standing on any flat surface or rack mounted in any 19-inch or Eurorack cabinet.

! CAUTION

- ▶ **DO NOT** locate the control unit near or adjacent to heat producing equipment such as ovens, high wattage lamps, etc.

NOTE

- ▶ When rack mounting the 9040 Cascade control unit in a 19-inch cabinet or Eurorack, it may be necessary to remove the rubber feet from the bottom of the 9040 enclosure.

INPUT CONNECTIONS

For non-conduit installations, plug the detachable AC line cord into the receptacle in the rear of the 9040 Cascade control unit. Plug the other end of the line cord into a properly grounded 120-volt AC outlet.

NOTE

- ▶ In general, conduit must be used for approved AC installation; however, if national and local codes permit, the AC power may be supplied via the factory supplied line cord. If conduit is utilized, the control unit AC input wiring may be routed through an optional explosion proof switch mounted on or near the spray booth where it will be convenient to the operator.

For installations where it is required to run the AC input wiring in conduit, perform the following:

1. Ensure the AC line cord is unplugged and remove the AC Inlet Receptacle wiring from 1TB-L1, 1TB-N and 1TB-Ground (see Figure 2 for AC input wiring locations).

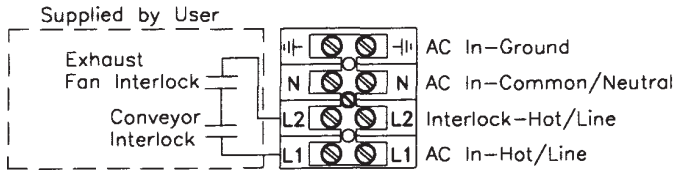

Figure 2: Terminal Block One (1TB)

! WARNING

► Always double check that the control unit is unplugged from its AC outlet before working with any internal wiring connected to 1TB-L1, 1TB-L2, 1TB-N, 1FU, 1SW, or 8PL.

2. Remove the mounting hardware from the AC Inlet Receptacle and remove it from the rear of the control unit.
3. Install the Conduit Adapter Plate (supplied) in the hole where the AC Inlet Receptacle was removed (see Figure 3).
4. Install the AC line cord through the Conduit Adapter Plate using conduit and wire to TB1 as follows:

Hot/Line	to	1TB-L1
Neutral/Common	to	1TB-N
Ground	to	1TB-Ground

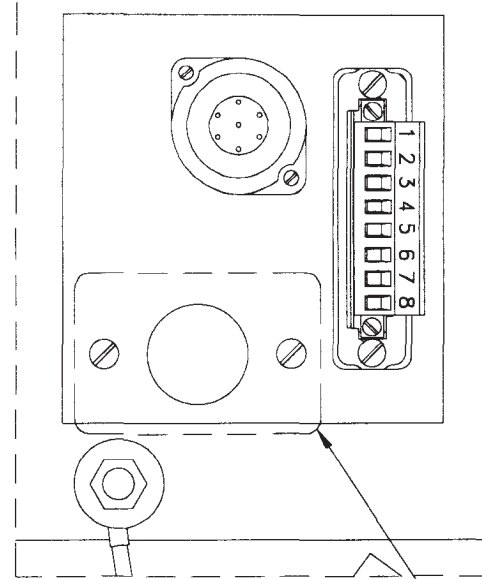

Conduit Adaptor Plate

Figure 3: Installation of Conduit Adaptor Plate

NOTE

► When using conduit to route the AC input wiring to the control unit, the last several feet of conduit attached to the control unit should be of a flexible type, such that the control unit module can still be slid out of the enclosure for testing and setup purposes.

The 9040 Cascade control unit accepts universal input voltage between 90 and 264 VAC. There is no need to change any switch settings when changing input from 115 to 230 VAC or vice-versa.

NOTE

► 9040 units shipped from the factory for 115 VAC input will have a 72771-06, 1 amp front panel fuse installed. While 9040 units shipped from the factory for 230 VAC input will have a 72771-01, 0.5 amp front panel fuse installed. If the other input is required, it is recommended that the fuse be changed in order to keep the same level of protection. Both fuses are shipped with 9040 control units.

EXTERNAL CONNECTIONS

NOTE

► When connecting external wires to the 9040 Cascade control unit, some of the wires will be connected to the External Wiring Plug 2PL and some routed through the External Wiring Grommet. When wiring through the External Wiring Grommet, leave enough slack in the wires so that the 9040 control unit chassis can still be slid out of its enclosure if required. For installations requiring conduit, route all wires through the external wiring grommet opening and connect to the existing wires on the inside of External Wiring Plug 2PL (2SOF) when necessary.

Low Voltage Cable Connection

Connect the low voltage cable from the spray applicator to the Low Voltage Cable Socket located on the back of the control unit. Hand tighten only.

Connect the other end of the low voltage cable to the applicator, using a wrench to tighten.

For 78398-OX 9040 control units, connect the low voltage cable from the low voltage cable socket on the rear of the control unit to the low voltage input receptacle on the side of the 76300-XX External Cascade.

CAUTION

► **DO NOT** over tighten low voltage cable connection to applicator. Damage to plastic parts may occur.

Safety Ground

Crimp the appropriate connector onto the Ground Wire Assembly and install from the control unit ground stud, located on the back of the control unit to a true earth ground.

CAUTION

► The Ground Wire Assembly **MUST** be connected from the power supply ground stud to a true earth ground. Supplemental ground is provided via the ground stud to the enclosure, through the front panel screws, and to the chassis module. Therefore, ensure the front panel screws in the 9040 Cascade control unit module are securely fastened to the rack enclosure during operation. If it becomes necessary to slide the chassis out for testing purposes, connect a ground wire from the enclosure to the chassis.

Interlocks

WARNING

► **ALWAYS** ensure that high voltage is **OFF** before flushing the spray applicator with solvent. **NEVER** flush the spray applicator with high voltage **ON**, as this is a severe fire hazard and risk to personnel safety. It is recommended that the high voltage control be interlocked with the solvent flush signal so that high voltage is automatically locked out whenever flushing occurs. Consult your authorized ITW Ransburg representative for information on interlocking the high voltage **OFF** signal with the solvent flush signal.

As outlined in NFPA-33 and OSHA, the AC power line must be series interlocked with both the exhaust fan and conveyor. To interlock the 9040 Cascade control unit with the exhaust fan and conveyor perform the following:

1. Ensure the front panel fuse is removed, the control unit is unplugged, and the ON/OFF switch is in the OFF position.
2. Loosen the front panel screws and slide the control unit chassis out.

⚠ WARNING

► Always double check that the control unit is unplugged from its AC outlet before working with any internal wiring connected to 1TB-L1, 1TB-L2, 1TB-N, 1FU, 1SW, or 8PL.

3. Using a small blade screwdriver, remove the factory installed test jumper from 1TB-L1 to 1TB-L2.
4. Route exhaust fan and conveyor interlock (supplied by user) wiring through external wiring grommet on the back of the control unit and connect to 1TB-L1 and 1TB-L2 as shown in Figure 2. **The interlock contacts should be rated for at least 1 amp at 240 volts AC.**
5. Slide the chassis back in, secure the front panel screws, replace the fuse, and plug the control unit in.

⚠ CAUTION

► When highly conductive, solvent-based paints are used it is also recommended that the high voltage control be series interlocked with the atomization air. This prevents the possibility of a charged stream of fluid creating an arc, and subsequent fire, as it approaches the floor (or some other grounded object). Consult your authorized ITW Ransburg representative for information on interlocking the high voltage with the atomization air.

External Relay Contacts

A set of external relay contacts for high voltage (K1) and overload (K2) conditions is provided at External Wiring Plug 2PL-5, -6 & -7 (outside) and 2SOC-5, -6 & -7 (inside). (See Figure 11 for exact wiring locations.) These relay contacts are sometimes useful in configuring the control of the spray applicator system.

Maximum contact ratings are as follows:

	DC	AC
Maximum Switching Power	60W	125VA
Maximum Switching Voltage	220VDC	250VAC
Maximum Switching Current	2A	2A

Pneumatic Connections

76580-1XXXX, -6XXXX, and -7XXXX

Connect the Air Filter Assembly (supplied) to the IN port of the air flow switch on the back of the 9040 Cascade control unit. Connect regulated (100 psi maximum) factory air to the other end of the Air Filter Assembly. Be sure that the fittings remain clean and are securely tightened. Attach the spray applicator air line to the OUT port of the air flow switch.

When the spray applicator is triggered, the resulting air flow closes the contacts of the air flow switch, thereby activating high voltage at the spray applicator.

76580-4XXXX, -5XXXX, -8XXXX, and -9XXXX

Connect an atomization air pressure signal to one pressure switch port and a trigger air pressure signal to the other. When pressure signals are applied to both switches, their contacts close thereby activating high voltage at the spray applicator. Both pressure switches must be activated to receive high voltage. Pressures greater than 15 psi are required to activate the pressure switches. Maximum operating pressure is 150 psi.

External High Voltage Control

If a method of high voltage triggering, other than the factory supplied method, is required, the 9040 Cascade control unit allows for external high voltage control from a PLC, pressure switch, airflow switch, or other user-supplied device. To turn the high voltage on, the user-supplied device must create a contact closure between terminals 1 and 2 of the External Wiring Plug (2PL). The wiring from the user-supplied external high voltage control device can be connected directly to the outside terminals of 2PL, or for installations requiring conduit, connected to the inside terminals 2SOC-1 and 2 as follows:

1. Ensure the front panel fuse is removed, the control unit is unplugged, and the ON/OFF switch is in the OFF position.
2. Loosen the front panel screws and slide the control unit chassis out.
3. Route the contact wires of the control device through the external wiring grommet opening and connect to the existing wiring for 2SOC-1 and 2SOC-2. **The control device contacts must be rated for at least 100 milliamps at 15 volts DC.**
4. Slide the chassis back in, secure the front panel screws, replace the fuse, and plug in the control unit.

NOTE

► A separate normally open (NO) external high voltage control contact **MUST** be used for each control unit in multiple control unit applications. One contact **CAN-NOT** be used to trigger the high voltage for multiple control units.

External Overload Reset

The 9040 Cascade control unit allows for use of an external (normally closed) overload reset button. This is convenient when the control unit is mounted in a hard to reach or inconvenient location or when it is desired to control overload reset of several control units from a single location.

NOTE

► A separate normally open (NO) external high voltage control contact **MUST** be used for each control unit in multiple control unit applications. One contact **CAN-NOT** be used to trigger the high voltage for multiple control units.

The wiring from the user supplied external overload reset device can be connected directly to the outside terminals 2PL-2 and -3 (remove factory installed jumper from 2PL-2 to 2PL-3), or for installations requiring conduit, connected to the inside terminals 2SOC-2 and 3 as follows:

1. Remove the factory-installed jumper from 2PL-2 to 2PL-3.
2. Ensure the front panel fuse is removed, the control unit is unplugged, and the ON/OFF switch is in the OFF position.
3. Loosen the front panel screws and slide the control unit chassis out.
4. Route the contact wires of the external reset device through the external wiring grommet opening and connect to the existing wiring for 2SOC-2 and 2SOC-3. **The external reset device contacts must be rated for at least 100 milliamps at 15 volts DC. The contacts of the external reset device must be normally closed.**
5. Slide the chassis back in, secure the front panel screws, replace the fuse, and plug in the control unit.

Analog Current Output Signal

An analog current output signal is available from the 9040 control unit at 2PL-8 (outside) or 2SOC-8 (inside). This signal can be connected to a recording device (strip chart recorder, data acquisition unit, etc.) to monitor the output current of the control unit over time. This signal should be referenced to earth ground. The input resistance of the recording device should be 5 megohms or greater.

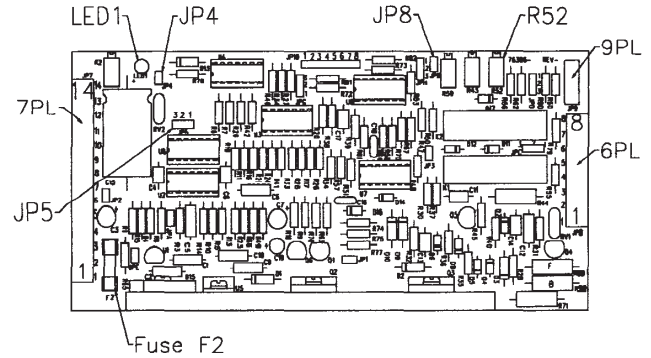

Figure 4: Main PC Board

NOTE

- ▶ If the input resistance of the recording device is less than 5 megohms, it will affect the reading on the 9040 control unit microammeter.

The analog current output signal can be adjusted such that 0 to 10 VDC represents 0 to 100 microamps or 0 to 200 microamps, by opening or shorting jumper JP8 on the main PC board (see Figure 4 for JP8 location). The board is factory supplied with JP8 shorted (covering both terminals) such that 0 to 10 VDC represents 0 to 200 microamps. To set the analog output current so that 0 to 10 VDC represents 0 to 100 microamps open jumper JP8 (reposition so that it covers only one terminal).

The wiring from the user supplied analog output current recording device (with input resistance of 5 megohms or greater) can be connected directly to outside terminal 2PL-8, or for installations requiring conduit, connected to the inside terminal 2SOC-8 as described below. Connect common of the recording device directly to earth ground.

1. Ensure the front panel fuse is removed, the control unit is unplugged, and the ON/OFF switch is in the OFF position.
2. Loosen the front panel screws and slide the control unit chassis out.

3. Route the wire of the external recording device through the External Wiring Grommet opening and connect to the existing wiring for 2SOC-8.
4. Slide the chassis back in, secure the front panel screws, replace the fuse, and plug the control unit back in.

Triple Set Point/Analog Input Control Connections

(76580-4XXXX, -5XXXX, -8XXXX, and -9XXXX only)

9040 Cascade control units for automatic applicatorss are shipped with a combination Triple Setpoint/Analog Input Interface Board installed. When set for triple setpoint operation, three discreet setpoints for high voltage output at the spray applicator can be selected, using two 24 VDC input signals. When set for analog input operation a 0 – 10 VDC or 4 – 20 mADC input signal can be used to select continuous kV output at the spray applicator from 0 to rated kV. With either setting a PLC, robot, ext. can thus select from different voltages to suit the spray application.

To utilize the Triple Setpoint Feature perform the following (refer to Figures 5a and 5b):

1. Ensure the front panel fuse is removed, the control unit is unplugged, and the ON/OFF switch is in the OFF position.
2. Loosen the front panel screws and slide the control unit chassis out.
3. Ensure JP2 jumpers on triple set point/analog input board are set to TSP ON position as shown on PC board silkscreen.
4. Route the wiring through the External Wiring Grommet and connect to the Triple Setpoint Board as follows:

Robot or PLC Common	to	TB1-2
24 VDC Setpoint 1 Select	to	TB1-1
24 VDC Setpoint 2 Select	to	TB1-3

NOTE

- ▶ An interlock line with the control unit power and overload signal is provided across terminals TB1-4 and 5. This line can be used to indicate that high voltage is ready (control unit is on and not in overload state) if desired.

5. Slide the chassis back into the cabinet, secure the front panel screws, replace the fuse, and plug the control unit in.

The Triple Setpoint Board is now ready for use. Turning on the robot or PLC output connected to TB1-1 will activate Setpoint 1, while turning on the robot or PLC output connected to TB1-3 will activate Setpoint 2. The third setpoint is determined by the setting of the control unit High Voltage Adjust Knob when both robot or PLC outputs are off.

High voltage outputs selected by TB1-1 (Setpoint 1) and TB1-3 (Setpoint 2) can be adjusted by tweaking potentiometers P1 and P2 on the Triple Setpoint Board, respectively. Typically P1 is factory set to provide approximately 50% of maximum kV, while P2 is set to provide approximately 75% of maximum kV.

NOTE

- ▶ Jumper J1 on the Triple Setpoint Board should be positioned so that it covers only one terminal (open) for proper operation. Turn the control unit power OFF before flushing, cleaning, or servicing the applicator.

To utilize the Analog Input Feature perform the following (refer to Figure 5b):

1. Ensure the control unit is OFF < unplugged from the AC outlet, and the front panel fuse is removed.
2. Loosen the front panel screws and slide the control unit chassis out.
3. Set JP2 jumpers on Triple Setpoint/Analog Input Board to ANLG ON position as shown on PC board silkscreen.

NOTE

- ▶ When JP2 is set to TSP ON position and no 24 VDC triple setpoint inputs are applied, high voltage control is from the High Voltage Adjust Knob on the front of the control unit.

4. Set JP3 jumpers on Triple Setpoint/Analog Input board to desired input (0 to 10 VDC or 4 to 20 mADC) position, as shown on PC board silkscreen.

CAUTION

▶ **DO NOT** operate the Analog Input Feature with the jumpers removed from JP2 or JP3, or with the jumpers in any other positions that those shown on the PC board silkscreen.

CAUTION

▶ **DO NOT** use the analog input board as a method for turning high voltage ON and OFF. The control unit has specific inputs for this purpose (see “Pneumatic Connections and External High Voltage Control” in this section).

▶ **ALWAYS** turn the control unit’s AC Power ON/OFF switch to the OFF position before flushing, cleaning, or serving the applicator.

5. Connect the positive analog control input (source) to TB1-6 and the negative analog input (common or return) to TB1-7. Route the wiring through the external wiring grommet on the rear of the 9040 control unit.

NOTE

▶ To eliminate problems caused by external noise, a twisted, shielded pair should be used for the analog input control wiring. Connect the shield to ground at the analog control source **ONLY**.

NOTE

▶ The input resistance of the Analog Input Board feature is:

0-10 VDC Operation: 200 Kiloohms
 4-20 mADC Operation: 249 Ohms

5. An interlock line with the control unit power and overload signal is provided across terminals TB1-4 and 5. This line can be used to indicate that high voltage is ready (control unit is on and not in overload state) if desired.

6. Slide the chassis back into the cabinet, secure the front panel screws, replace the fuse, and plug the control unit in.

The Analog Input board is now ready for use. A 0-10 VDC or 4-20 mADC input signal will produce an applicator output of 0 to rated kV.

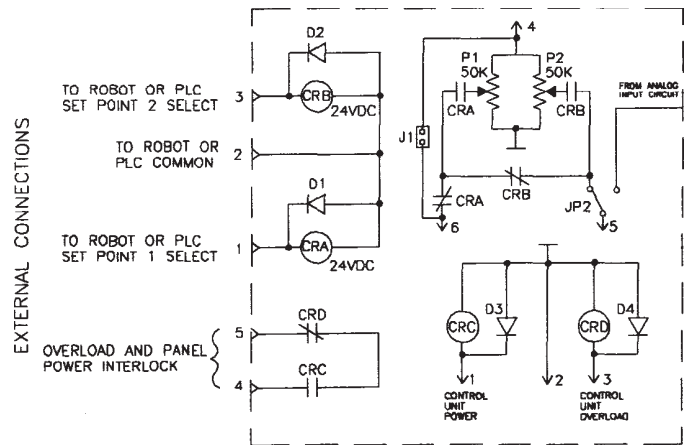

Figure 5a: Triple Setpoint Schematic

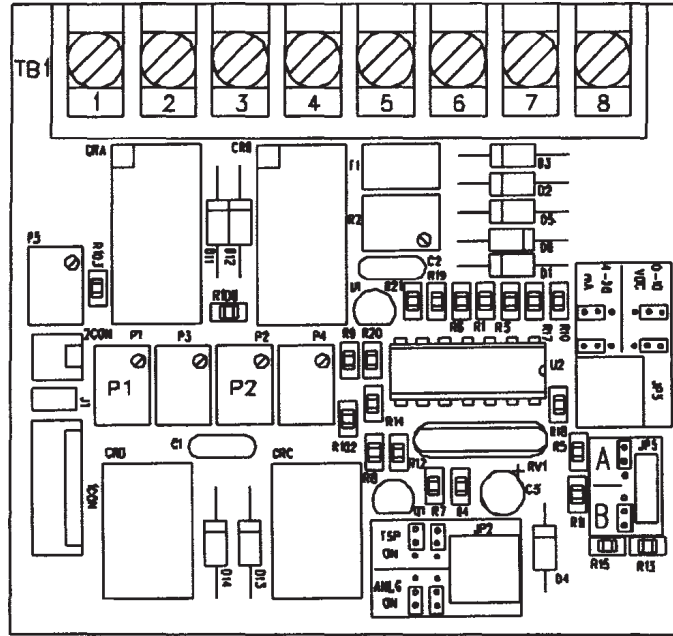

Figure 5b: Combination Triple Setpoint/Analog Input Board Layout

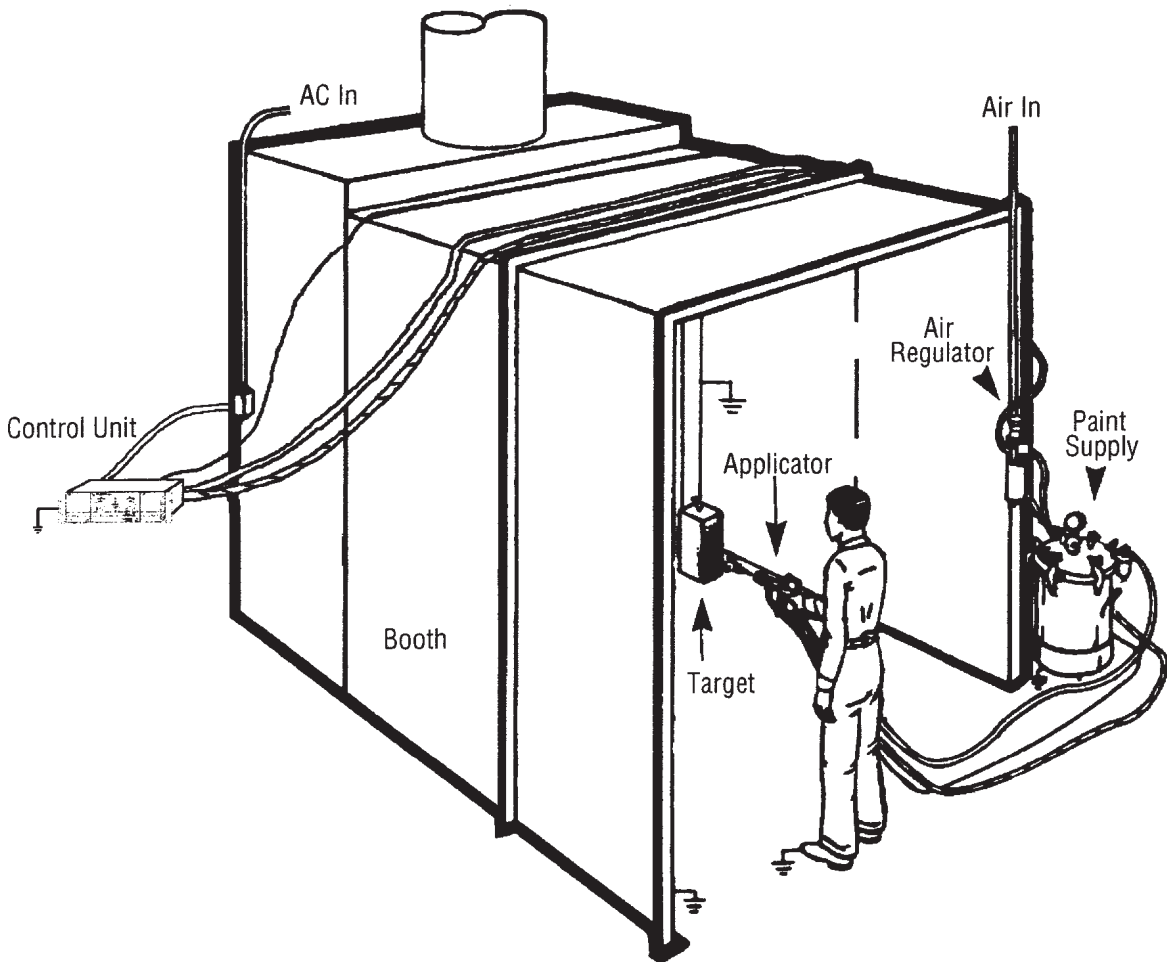

Figure 6: Typical REA Applicator Installation

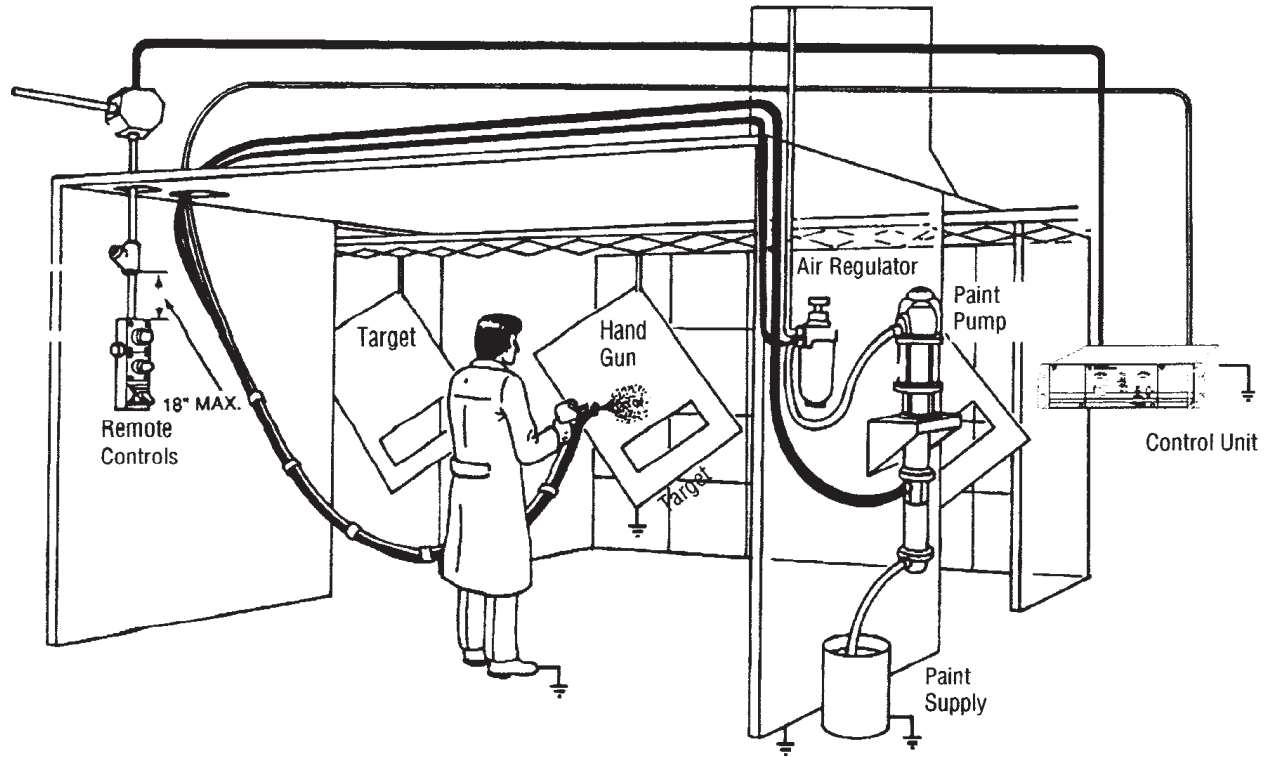

Figure 7: Typical REM Applicator Installation

OPERATION

! WARNING

► The user **MUST** read and be familiar with the **SAFETY PRECAUTIONS** and **SAFETY SECTIONS** of this manual and the ITW Ransburg safety literature therein identified **BEFORE OPERATING** the 9040 Cascade control unit.

! WARNING

► The electrical discharge that is available from the charging electrode of the applicator must not exceed 0.25 mJ of energy. To achieve this limit, any flow of energy from the paint supply through the paint line to the applicator electrode must be prevented by grounding the paint line at the applicator handle or body.

► Verify that the applicator is actually grounded before operating it! (See the appropriate applicator manual.) If improper readings are obtained, check that the control unit is grounded. (See “Ground Test Procedures” in the “Maintenance - Troubleshooting” section of this manual.)

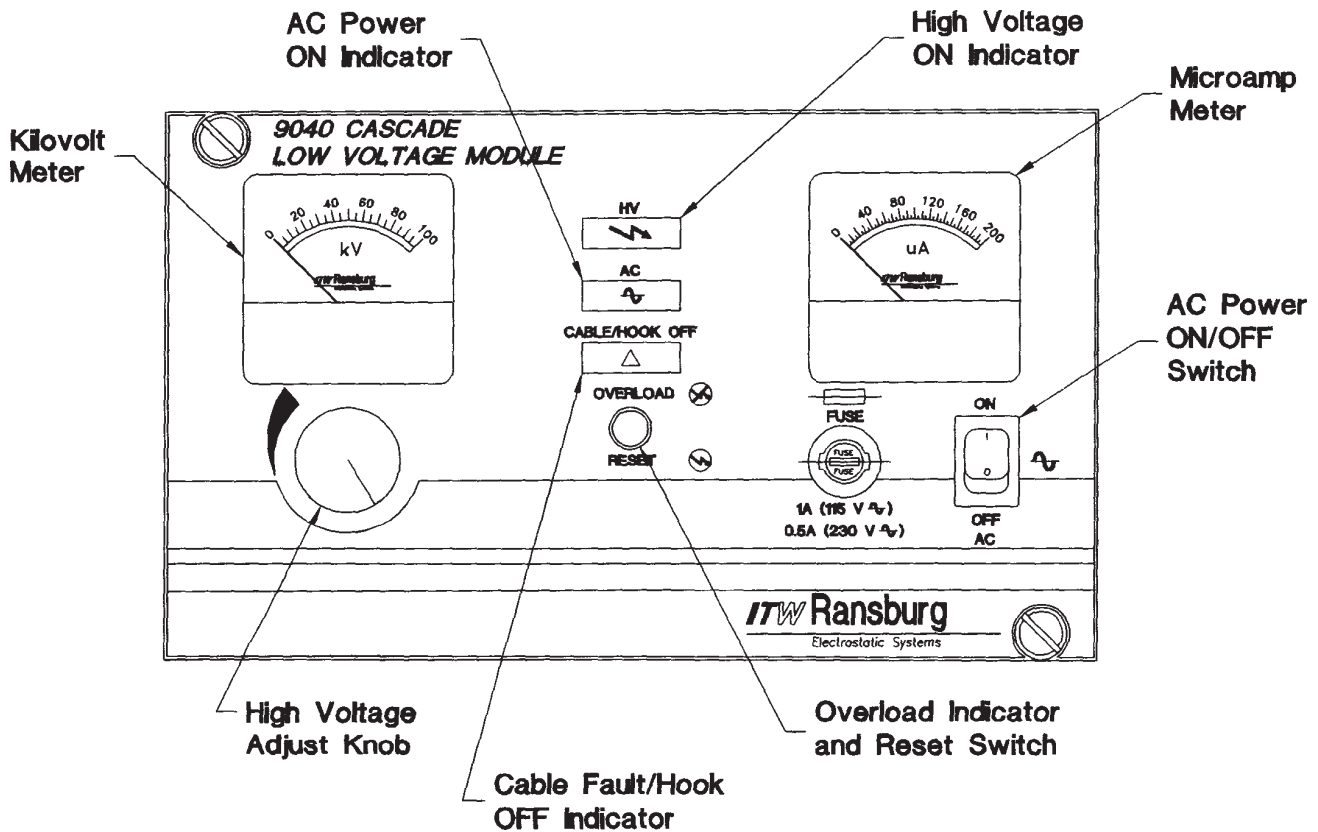

Figure 8: Operating Controls

OPERATING PROCEDURES

1. Ensure that the AC power, pneumatic and low voltage cables are connected as described in the “Installation” section of this manual.

 CAUTION
<p>► Check that the control unit is properly grounded!</p>

2. Be sure that the high voltage adjustment knob is turned FULLY counter-clockwise.

3. Turn the ON/OFF switch to the ON position. The green LED will light indicating that AC power is being supplied to the control unit.

4. The voltage to the REA-70 and REA-90 applicators is activated by supplying adequate air to the flow switch when the applicator is triggered. The voltage to the REM applicator is activated by a magnet in the applicator air valve assembly which triggers a reed switch inside the low voltage cable assembly. The voltage to automatic applicators is activated by supplying adequate pressure signals to the control unit pressure switches or by triggering an external high voltage control device connected across 2PL-1 and 2PL-2.

5. Turn the voltage adjustment knob to the desired operating point as indicated by the kilovolt and microamp meters.

Kilovolt and Microamp Meters

The kilovolt meter indicates the voltage in thousands of volts (kv) present at the applicator electrode. The microamp meter indicates the current in millionths of amps (uA) leaving the applicator electrode.

High Voltage Adjustment Knob

The high voltage adjustment knob allows infinite control of the applicator electrode voltage between 0 and rated kV.

Overload Indicator/Reset Button

Lighting of the yellow overload/reset lamp indicates that an overload condition has occurred. The overload circuitry is integral to the control unit and is factory calibrated and sealed. It allows normal operation, testing and maintenance. It will only activate if the spray applicator load conditions exceed the pre-set limit as a result of component (barrel, transformer, cable) failure or improper applicator to target distance. If the overload should trip, locate and correct the problem. Then reset the overload by pushing the reset switch in, or turning the ON/OFF switch OFF and back ON again.

The overload feature can be turned ON or OFF by moving jumper JP5 on the main PC board (see Figure 4 for location of JP5). To turn the overload circuit OFF position jumper JP5 so that it covers (shorts) pins 2 and 2. To turn the overload circuit ON position jumper JP5 so that it covers (shorts) pins 2 and 3.

<h3>NOTE</h3>

► Control units for applicators are shipped from the factory with the overload circuit OFF, while those for automatic applicators are shipped with the overload circuit ON. This is because during normal use, manually operated applicators may come in close proximity to the part, causing an overload which requires the operator to cease the painting operation while going to reset the overload. In addition, the operator will notice when a failed part may be causing the applicator to operate at less than optimum performance, thus the overload circuit is not necessary for this purpose.

Automatic applicators, however, typically have a fixed distance between electrode and target and thus it is not likely that the spray applicator would come into close proximity with the part during normal use. If it should, then it is desired that an overload occur to alert maintenance so that the condition may be corrected. Additionally, since there is no operator with automatic applicators, the overload circuit is required to alert maintenance when failed parts may be causing the applicator to operate at less than optimum performance.

When turning the overload circuit ON for applicator units it may be necessary to adjust the setpoint at which overload occurs. If so, contact your authorized ITW Ransburg representative for assistance.

High Voltage Safety Circuit

The 9040 Main PC board contains a safety circuit that prevents high voltage from being present at the applicator if the high voltage trigger device (flow switch, pressure switch, PC contact, etc.) has not been triggered. If a failure mode should occur that would attempt to send high voltage to the applicator, even though the high voltage trigger has not been activated, the PC board will shut down and enter an overload condition. If the control unit repeatedly overloads even though the high voltage trigger has not been activated, the main PC board has failed and should be replaced.

High Voltage ON Indicator

The red AC power ON LED will light when the AC Power ON/OFF switch is in the ON position.

Cable Fault/Hook OFF Indicator

The yellow cable fault/hook OFF LED will light whenever the low voltage signal to the applicator is open circuited. This will occur if the cable is not connected or if the cable becomes damaged such that power cannot be transmitted to the applicator. With applicators having hook transformer mounted ON/OFF switches, the cable fault/hook OFF indicator will also light when the switch is placed in its OFF position.

NOTE

- Because of the manner of high voltage triggering employed in the REM applicator, the Cable Fault/Hook OFF Indicator will not function if either wire to the reed switch, located in the applicator handle, becomes open circuited (such as when the cable is disconnected or completely cut through).

NOTES

MAINTENANCE

ROUTINE PREVENTIVE MAINTENANCE

In general, little maintenance is necessary to ensure proper operation. It is important, however, to keep the interior of the unit clean and free from moisture or foreign material. For this reason:

- Keep the exterior of the unit free from dust accumulation.
- Always clean the exterior prior to accessing the interior.
- Access the interior only to perform maintenance or repair.

TROUBLESHOOTING

Ground Test Procedure

Equipment Required: Ohmmeter - to measure resistance

If shocks or sparks are noticed at any point in the spray system, immediately turn off the control unit and check the complete system for proper grounding. Proper grounding of the applicator system can be verified as follows:

1. Ensure that the clamp of the Ground Wire Assembly is connected to true earth ground. The resistance between the clamp and a known earth ground should read less than 25 ohms.
2. Place one end of the ohmmeter on the clamp of the ground wire assembly and the other end on the control unit ground stud. If the ohmmeter reads greater than 25 ohms replace the Ground Wire Assembly.

3. Disconnect the low voltage applicable cable and connect one lead of the ohmmeter to the ground stud and the other to the center pin of the low voltage cable socket on the control unit. If the ohmmeter reads greater than 25 ohms, repair the internal connections between these points (green wires from 1TB-GROUND TO 1GND (see Figure 10) and from 1TB-GROUND to center pin of low voltage cable socket).

NOTE

- ▶ In the control unit, ground is passed from the ground stud to the chassis via the front panel screws. Ensure the front panel screws are securely fastened and repeat step 3 before searching for faulty internal connections.
-

4. Connect one end of the ohmmeter to the center pin of the low voltage cable connector on the cable, and the other to the metal applicator body (automatics) or handle bracket (applicators). If the ohmmeter reads greater than 25 ohms replace the low voltage cable.

NOTE

- ▶ On applicators, ground is passed from the low voltage cable to the handle via the handle set screw. Ensure the set screw is completely tightened and repeat step 4 before replacing the low voltage cable on applicator units.
-

Control Unit Output Test

When a lack of high voltage at the applicator indicates a problem, perform a Control Unit Output Test on the control unit to determine whether it is at fault.

Equipment Required: ITW Ransburg LTST5000 LV Control Unit Test Assembly

1. Turn control unit power OFF and remove low voltage cable from control unit.
2. Connect tester cable to control unit.
3. Move switch on tester to FRONT PANEL kV METER position.
4. Turn control unit ON and adjust control unit high voltage adjust knob fully clockwise.
5. Read the control unit front panel kV meter. Reading should be rated kV of applicator ± 5 kV. turn the control unit OFF.

If the voltage read correctly, the problem is not in the control unit and the low voltage cable and applicator should be checked for the cause. If proper readings are not obtained, the problem is with the control unit. Consult the "Troubleshooting Flowchart" in this section to locate the specific problem.

NOTE

- ▶ The LTST5000 Test Assembly can also be used to test the low voltage cable. Consult the LTST5000 service manual for further information on using the LTST5000 Test Assembly.

PC Board Test Jumper

To assist in testing and troubleshooting, a jumper (JP4) has been incorporated on the 9040 PC board. By covering (shorting) both terminals the high voltage on relay is triggered. Thus, for testing and troubleshooting, high voltage output can be obtained without the need to trigger the applicator or user supplied control device. Just remember to reposition the jumper after testing, so that it covers only one terminal (open) or the high voltage will stay on all the time. (See "Figure 4 - Main PC Board" for location of test jumper JP4.)

CAUTION

- ▶ **If JP4 is left covering (shorting) both terminals, high voltage will be on whenever AC power is turned on. This could be hazardous in some applications.**

Theory of Operation

Line voltage (90-264 VAC) is applied to input terminals 8PL-1 and 8PL-2 of power supply 1 SUP through the user supplied exhaust fan and conveyor interlocks, fuse IFU, and ON/OFF switch 1SW.

The output of power supply 1SUP, through PC board fuse F2, provides the DC voltage which powers the PC board regulators and the AC Power ON LED. The DC input to the oscillator circuit is obtained from a board regulator through high voltage adjust knob 1POT. The oscillator circuit outputs a low voltage, high frequency AC signal through the low voltage cable socket 3SOC to the applicator. The high voltage cascade located in the applicator rectifies the AC voltage to DC and steps it up to provide rated kV. The high voltage adjust knob controls the level of output voltage from the oscillator to the high voltage cascade. In this manner, complete adjustability from 0 to maximum kV of the applicator is achieved.

The DC input to the oscillator is interlocked with 2PL terminals 1 and 2, such that the oscillator will not function unless terminals 1 and 2 of 2PL are connected together. In this manner, high voltage to the applicator is controlled as follows:

1. When air flows through the flow switch, the switch contacts close connecting 2PL-1 and 2 together, thereby providing voltage to the REA-70 and REA-90 applicators.
2. Pulling the trigger on the REM applicator activates a reed switch in the applicator handle that connects 2PL-1 and 2 together, thereby providing voltage to the applicator.
3. When pressure signals are supplied to the pressure switches, the switch contacts close connecting 2PL-1 and 2 together, thereby providing voltage to automatic applicators.
4. Contact closure of a programmable controller output, robot output, or some other user supplied device connected to terminals 2PL-1 and 2 will activate high voltage at the applicator.
5. For testing and troubleshooting, board jumper JP4 connects 2PL-1 and 2 together, thereby providing high voltage output (see "PC Board Test Jumper" previously discussed in this section).

Bench Testing

NOTE

► Before going through the trouble of a complete bench test, jumper JP4 on the main PC board to trigger the high voltage and see if the suspected problem goes away. If it does, replace the high voltage trigger device (flow switch, pressure switch, PC contact, etc.) or repair the internal wiring of the control unit connected to the trigger device, and test again. If the problem does not go away then proceed with a bench test.

Equipment Required: Volt/ Ohmmeter

This section provides a flow chart for troubleshooting the control unit when improper operation is obtained and the problem has been traced to the control unit. Proper troubleshooting should ONLY be accomplished with specific test equipment, by qualified electronics technicians, or authorized ITW Ransburg representatives.

⚠ WARNING

► The troubleshooting procedure outlined in "Troubleshooting Flow Charts" requires measurement of voltage potentials that can cause **SERIOUS BODILY INJURY** if proper measuring procedures are not followed. For this reason, proper troubleshooting should ONLY be accomplished with specific test equipment by qualified electronics technicians or authorized ITW Ransburg representatives.

Before troubleshooting, ensure that the control unit is plugged into a live outlet of the appropriate voltage. All electrical measurements in the "Troubleshooting Flowchart" are nominal and may vary as much as +/- 10% depending on the test conditions and the test equipment used. Refer to "Figure 4 - Main PC Board" and "Figure 9 - Troubleshooting Diagram" for location of parts called out in "Troubleshooting Flowcharts".

For bench testing, jumper JP4 should be used to trigger the high voltage output (see "PC Board Test Jumper" previously discussed in this section).

NOTES

TROUBLESHOOTING FLOW CHARTS

ON / OFF Switch ON
ON / OFF Indicator (green LED) does not light

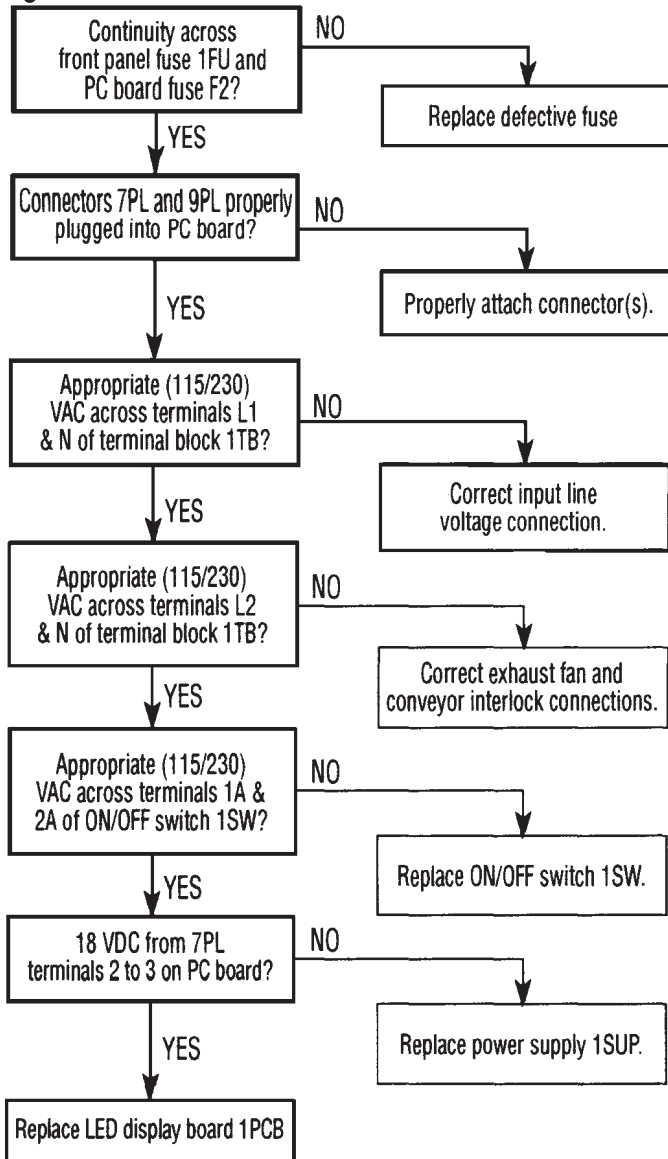

ON/OFF Switch ON
AC Power ON Indicator lit
HV ON Indicator (red LED) lit
No or low kV output at spraygun

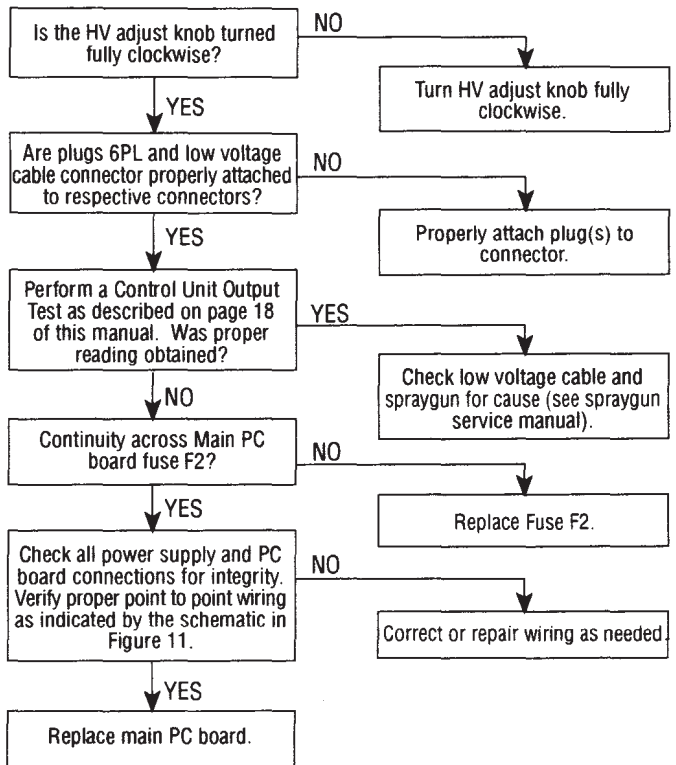

ON/OFF Switch ON
AC Power ON Indicator lit
HV ON Indicator does not light
No kV output at spraygun

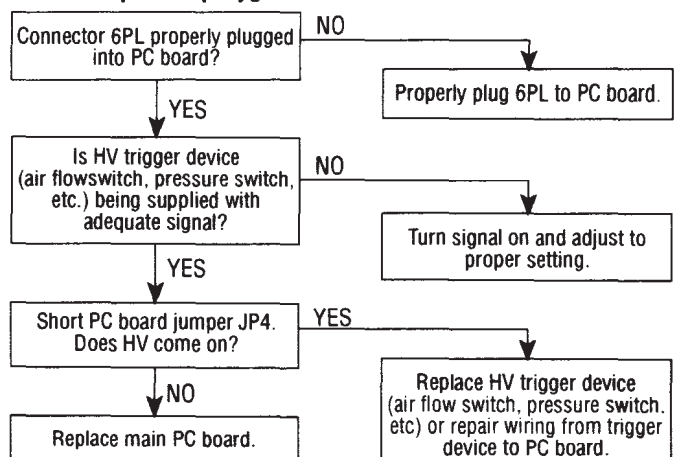

TROUBLESHOOTING FLOW CHARTS (Cont.)

Control Unit overloads excessively

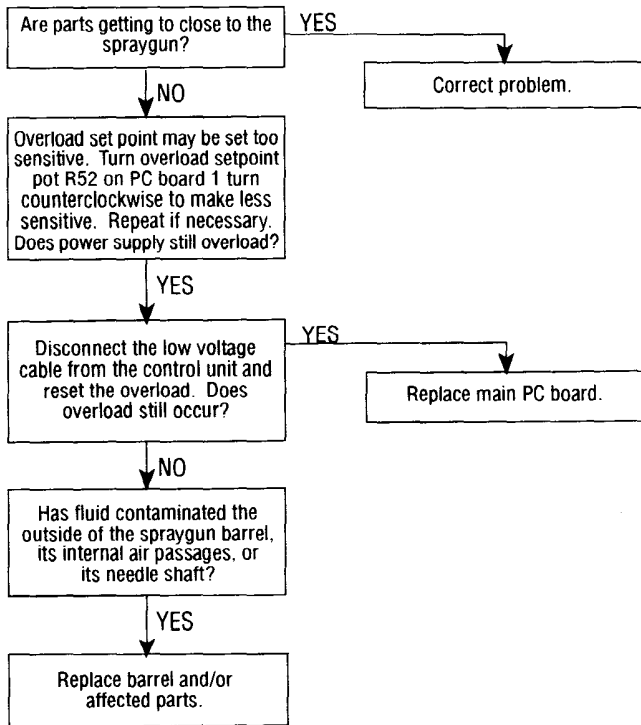

Component (kV or uA meter, HV ON indicator, AC Power ON indicator, HV adjust knob, etc.) not working properly but spraygun kV output is OK.

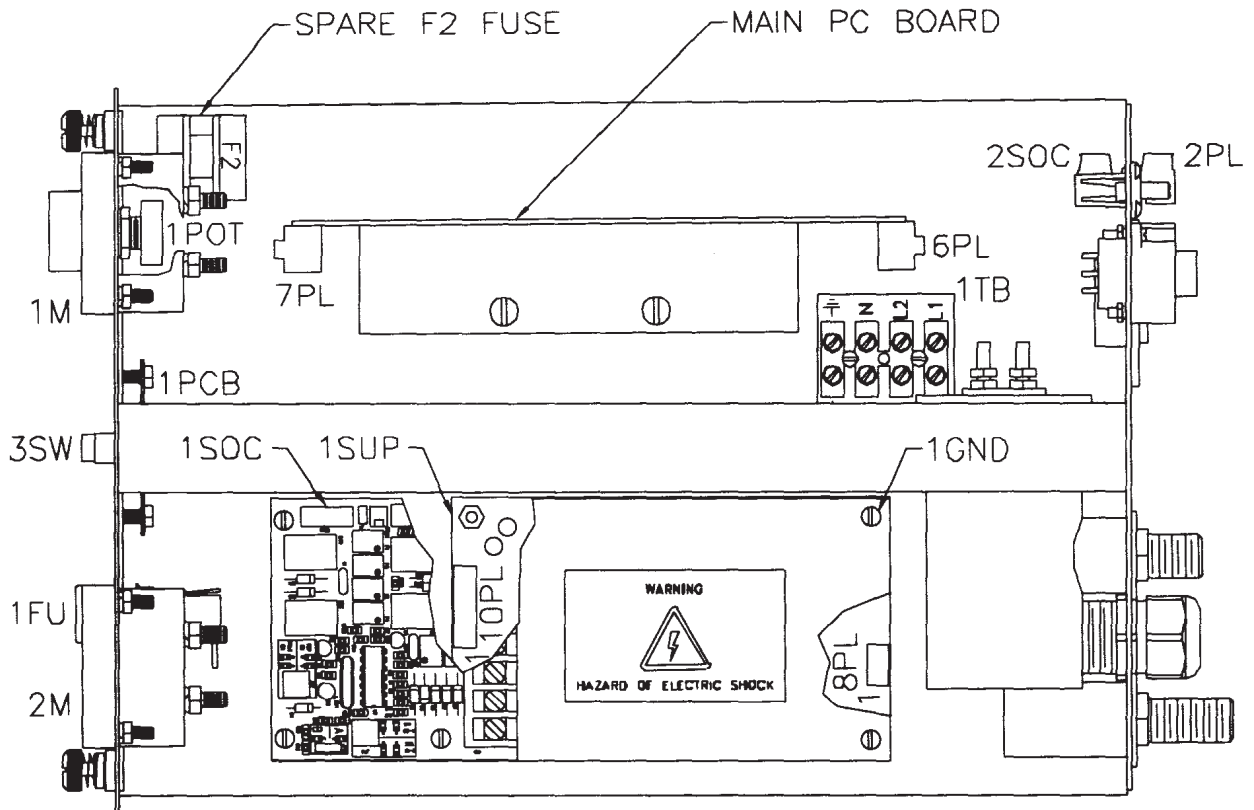
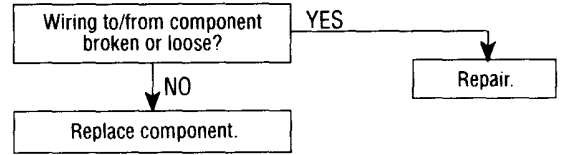

Figure 9: Troubleshooting Diagram

76892-XX PC BOARD ASSEMBLY

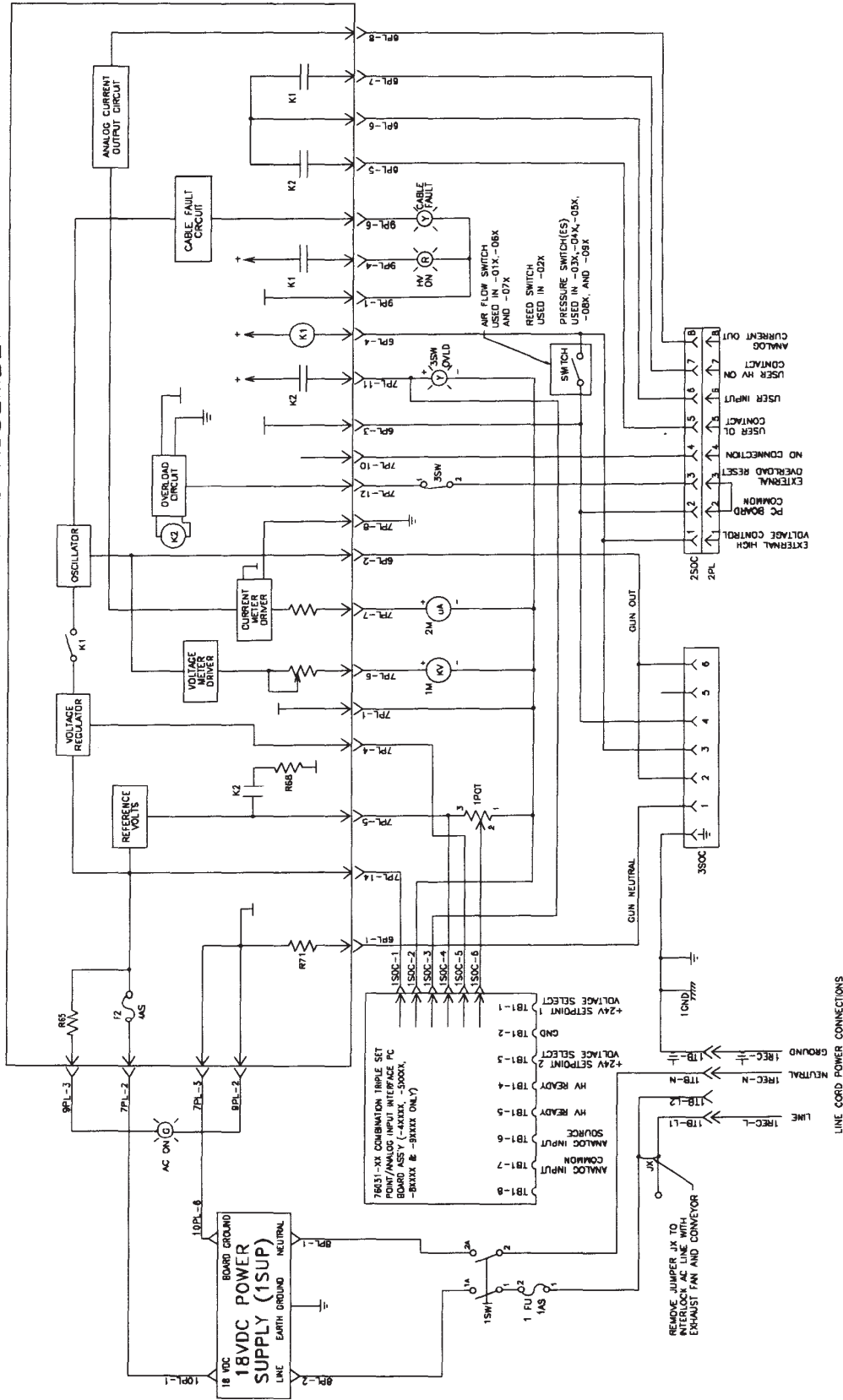

Figure 10: 9040 Cascade Control Unit Block Diagram

! WARNING

► Always turn power to the control unit OFF, unplug the electrical cord from its outlet, remove the front panel fuse, and lock the control unit out before making repairs or replacements.

SERVICE LEVEL

Personnel who service this unit must be qualified electronics technicians.

Replacement parts are designed to be made at the assembly level. (See “Parts Identification” section of this manual for replacement assemblies.)

! CAUTION

► Do not attempt to make repairs to the printed circuit board! Do not attempt to make repairs beyond those described. All others should be made ONLY by ITW Ransburg service personnel.

REPLACEMENT PROCEDURES

Before making replacements, check for defective wiring or connections between the affected components. If there is broken wire, defective insulation or dirty, loose or corroded connections, repair or replace them before going to the expense of replacing a component.

Front Panel Fuse 1FU

1. Insert screwdriver into slot in front panel fuse holder, push in, and rotate counter-clockwise.
2. Remove screwdriver and fuse holder will slide out.

3. Remove fuse from fuse holder and replace with new fuse (see “Parts Identification” section of this manual for fuse part number).
4. Insert fuse holder back into front panel and with a slight inward pressure, rotate screwdriver clockwise until it locks into place.

PC Board Fuse F2

(See Figure 4 for fuse location.)

1. Ensure control unit is unplugged from AC outlet, loosen front panel screws, and slide the control unit chassis out.
2. Replace defective fuse (see “Parts Identification” section of this manual for fuse part numbers).

NOTE

- A spare F2 PC board fuse is included from the factory. (See Figure 10 for location.)

3. Slide chassis in, secure front panel screws and plug control unit back in.

ON/OFF Switch 1SW

1. Ensure control unit is unplugged from AC outlet, loosen front panel screws, and slide the control unit chassis out.

! WARNING

► Always double check that the control unit is unplugged from its AC outlet before working with any internal wiring connected to 1TB-N, 1TB-L, 1TB-L2, 1FU, 1SW, or 8PL.

2. Remove the four (4) quick connect terminals from the rear of ON/OFF switch 1SW.

NOTE

► It is recommended that the four (4) ON/OFF switch wires be tagged with their respective terminal connections to 1SW before removing.

! WARNING

► Always double-check that the control unit is unplugged from its AC outlet before removing the cover plate from power supply 1SUP.

3. Press panel retaining clips on top and bottom of switch 1SW together and push switch out of panel from the inside.
4. Press new switch (see “Parts Identification” section of this manual to order) into panel opening with terminals 1A and 2A to the bottom of the cabinet.
5. Reconnect the four (4) quick connect terminals to the new switch as follows:

From	To
1FU-2	1SW-1
1TB-N	1SW-2
8PL-2	1SW-1A
8PL-1	1SW-2A

6. Slide chassis in, secure front panel screws, and plug control unit backing.

Power Supply 1SUP

1. Ensure control unit is unplugged from AC outlet, loosen front panel screws, and slide the control unit chassis out.
2. Remove the four (4) screws from the combination analog/triple setpoint board (if installed) and remove the board from the 1SUP power supply cover plate.
3. Remove the four (4) screws from the 1SUP power supply cover plate and remove the plate.

4. Remove connectors 8PL and 10PL from power supply 1SUP.
5. Remove the four (4) cover plate standoffs from power supply 1SUP and remove the power supply from the unit.
6. Install new 1SUP power supply (See “Parts Identification” section of this manual to order) using the four (4) cover plate standoffs. Ensure larger connector (10PL) of power supply 1SUP faces front of unit as shown in Figure 9.
7. Connect connectors 8PL and 10PL to new power supply and reinstall cover plate and analog/triple setpoint board.
8. Slide chassis in, secure front panel screws, and plug control unit back in.

Flow Switch 1FS (76580-1XXXX, -6XXXX, and -7XXXX)

1. Disconnect air lines from flow switch.
2. Ensure control unit is unplugged from AC outlet, loosen front panel screws, and slide control unit chassis out.
3. Remove two (2) wires from flow switch terminals.
4. Remove hex nuts from flow switch inlet and outlet.
5. Pull out defective flow switch.
6. Attach two (2) wires to new flow switch (See “Parts Identification” section of this manual for ordering information) terminals (it does not matter which one goes where).

7. With flow switch terminals pointing towards the main PC board, install new flow switch through chassis mounting holes.
8. Secure flow switch to side panel with two (2) hex nuts.
9. Slide chassis in, secure front panel screws, and plug control unit back in.
10. Reconnect air lines to flow switch.

Pressure Switch (76580-4XXXX, -5XXXX, -8XXXX, and -9XXXX)

1. Disconnect pressure signal input line from pressure switch.
2. Ensure control unit is unplugged from AC outlet, loosen front panel screws, and slide control unit chassis out.
3. Remove two (2) wires from pressure switch terminals.
4. Loosen hex nut from fitting and remove pressure switch and fitting from control unit.
5. Remove fitting from defective pressure switch and install on new pressure switch (see “Parts Identification” of this manual for ordering information).
6. Install new pressure switch in control unit by securing hex nut to fitting.
7. Attach two (2) wires to the NO (normally open) and C (common) terminals of the pressure switch (it does not matter which one goes where). Do not attach any wires to the NC terminal of the pressure switch.
8. Slide chassis in, secure front panel screws, and plug control unit back in.
9. Reconnect pressure signal input line to pressure switch.

LED Display Board

1. Ensure control unit is unplugged from AC outlet, loosen front panel screws, and slide control unit chassis out.
2. Unplug display board connector 9PL from main PC board.
3. Remove two (2) screws that mount display board to inside of front panel and remove display board from control unit.
4. Install new display board (see “Parts Identification” section of this manual for information) in control unit.
5. Reconnect connector 9PL to main PC board.
6. Slide chassis in, secure front panel screws, and plug control unit back in.

Kilovolt (kV) or Microamp (uA) Meter

1. Ensure control unit is unplugged from AC outlet, loosen front panel screws, and slide control unit chassis out.
2. Remove two (2) hex nuts from wiring terminals and remove wire lugs.
3. Remove four (4) hex nuts that mount meter to front panel.
4. Remove old meter and install new one (see “Parts Identification” section of this manual for ordering information).
5. Reconnect wire lugs to meter (purple wire goes to + terminal of meter).
6. Slide chassis in, secure front panel screws, and plug control unit back in.

HV Adjust Potentiometer

1. Remove knob from HV adjust potentiometer by using a 1/16" Allen wrench to remove the two (2) set screws.
2. Ensure control unit is unplugged from AC outlet, loosen front panel screws, and slide control unit chassis out.
3. Remove heat shrink tubing and unsolder the wires from HV adjust potentiometer 1 POT.

NOTE

► It is recommended that the three (3) wires be tagged with their respective terminal connections to 1POT before unsoldering.

4. Remove the hex nut securing 1POT to the front panel and remove 1POT.
5. Install the new potentiometer (see "Parts Identification" section of this manual for ordering information) in the front panel.
6. Using heat shrink tubing and appropriate solder techniques, solder the wires to the new potentiometer as follows:

From	To
7PL-1	1POT-1 *
1SOC-6	1POT-2
7PL-5	1POT-3
IM-	1POT-1 *

* Indicated 2 connections to the same point.

7. slide chassis in, secure front panel screws, and plug control unit back in.
8. Reinstall adjust knob using 1/16" Allen wrench.

PC Board

1. Ensure control unit is unplugged from AC outlet, loosen front panel screws, and slide control unit chassis out.
2. Disconnect plugs 6PL, 7PL, and 9PL (see Figure 4).
3. Remove two (2) screws from heat sink base and lift the PC board out.

CAUTION

► DO NOT remove the PC board from the heat sink as it is an integrated assembly.

4. Insert new PC board (see "Parts Identification" section of this manual for ordering information) and secure the two (2) heat sink screws.
5. Reconnect plugs 6PL, 7PL, and 9PL.
6. Slide chassis in, secure front panel screws, and plug control unit back in.

NOTES

PARTS IDENTIFICATION

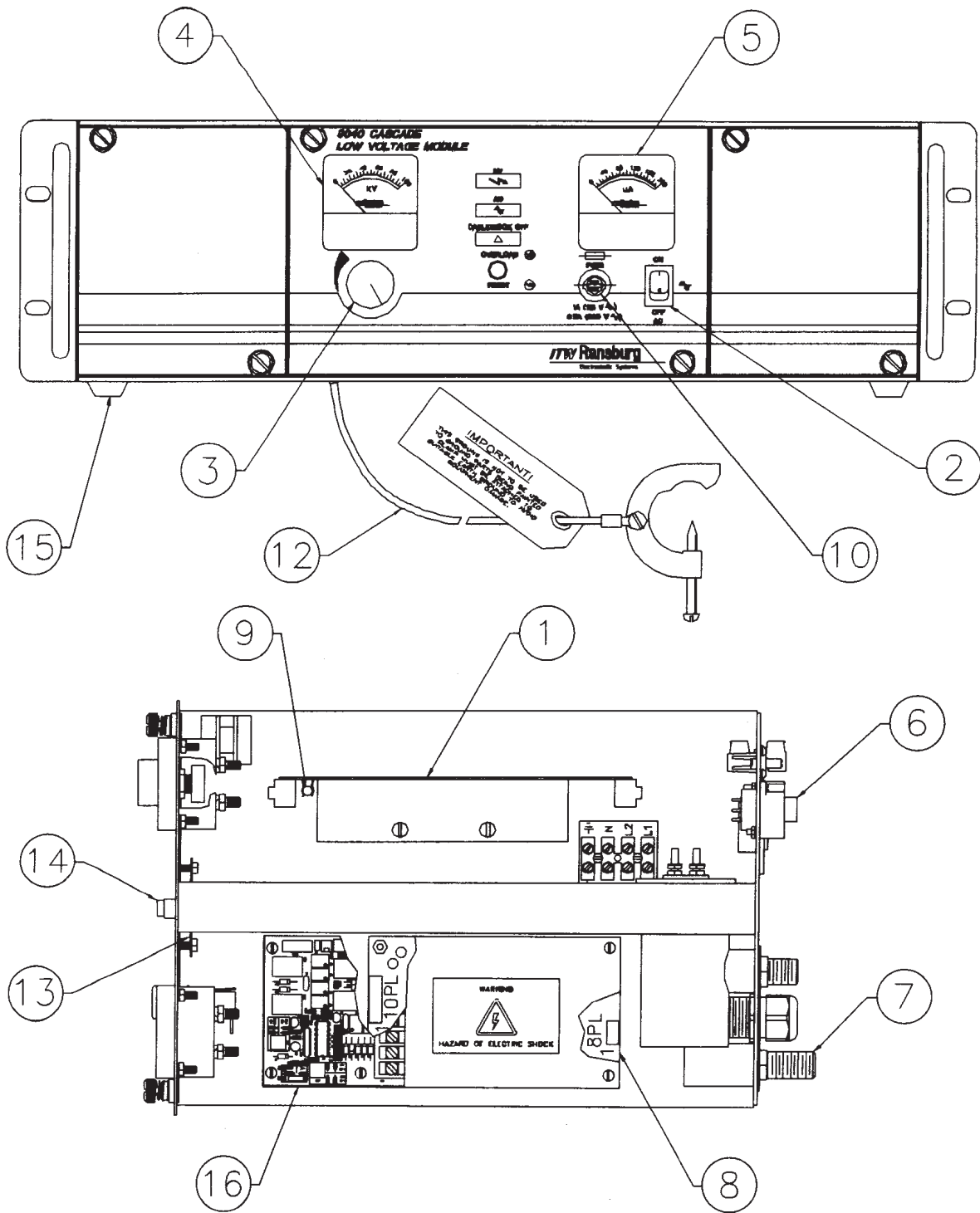

Figure 11: 9040 Cascade Low Voltage Control Unit Parts Diagram

9040 CASCADE LOW VOLTAGE CONTROL UNIT - PARTS LIST (Figure 11)			
Item #	Part #	Description	Notation
1		PC Board and Heat Sink Assembly:	
	76892-01	For 76580-1XXXX, REA70 Applicator (72074)	
	76892-02	For 76580-2XXXX, REM Applicator (72364)	
	76892-04	For 76580-4XXXX, REM Automatic (73499)	
	76892-05	For 76580-5XXXX, REA9000 Automatic (75795), Robot (76110), and 76580-BXXXX, REA900 Automatic (77359)	
	76892-06	For 76580-6XXXX, REA90 Waterborne Applicator (75786)	
	76892-07	For 76580-7XXXX, REA90 Solventborne Applicator (75785) and 76580-AXXXXX, M90 Applicator (77073)	
	76892-08	For 76580-8XXXX, REA90 Solventborne Automatic (75787X-XXXX1)	
	76892-09	For 76580-9XXXX, REA90 Waterborne Automatic (75787X-XXXX2)	
	76892-16	For 78398-01, Single Bell, Domestic	
76892-17	For 78398-02, Single Bell, Export		
2	76434-01	ON./OFF Switch	1SW
3	70556-03	High Voltage Adjust Potentiometer	1POT
4	76436-91	Kilovolt (kV) Meter	1M
5	76436-92	Microamp (uA)	2M
6	72231-00	Low Voltage Cable Socket	3SOC
7	13742-01	Air Flow Switch Assembly:	1FS
	13028-01	Housing	
	8012-00	Switch Assembly	
	6039-00	Piston	
	25766-106	Pressure Switch *	1PS, 2PS
8	75337-05	Power Supply, 18VDC	1SUP
9	LSME082-04	Fuse, PC Board, Slow Blow, 4 Amp (See Figure 5 for location.)	F2
10		Fuse, Front Panel:	
	72771-06	Slow Blow, 1 Amp, 110-120 VAC Input	1FU
	72771-01	Slow Blow, 0.5 Amp, 220-240 Input	1FU
11	76449-00	Detachable AC Line Cord	
12	70539-00	Ground Wire Assembly	
13	76455-01	LED Display Board	
14		Overload Indicator and Reset Switch Assembly:	
	76442-01	Reset Switch (normally closed)	
	76441-00	Lens, Yellow	
	76443-01	Bulb	
15	5627-00	Rubber Feet	
16		Triple Setpoint/Analog Input Interface Board:	
	76031-05	For REA90 Solventborne Automatic	
	76031-06	For 76580-8XXXX, REA90 Waterborne Automatic	
	76031-07	For 76580-4XXXX, REM Automatic	
	76031-08	For REA9000 Automatic or Robot	
	76031-10	For 78398-01, Single Bell, Domestic	
	76892-11	For 78398-02, Single Bell, Export	
	76895-18	For 76580-BXXXX, REA900 Automatic	

* Air flow switch used on 76580-1XXXX, -6XXXX, and -7XXXX.
 Pressure switches used on 76580-4XXX, -5XXXX, -8XXXX, and -9XXXX.

(Continued On Next Page)

9040 CASCADE LOW VOLTAGE CONTROL UNIT - PARTS LIST (Figure 11) (Cont.)			
Item #	Part #	Description	Notation
17		Totalizer Fluid Monitoring Module (all parts required to add Totalizer system to existing 9040 Rack):	
	76612-01	Intrinsically Safe U.S. Version (120VAC input with totals in gallons)	
	76612-02	Intrinsically Safe Export Version (240VAC input with totals in liters)	
	76612-03	Fiber Optic U.S. Version (120VAC input with totals in gallons)	
	76612-04	Fiber Optic Export Version (240VAC input with totals in liters)	
18		Pneumatics Module:	
	76613-11	Single Applicator Version	
	76613-21	Dual Applicator Version	
	76613-12	Single Automatic Applicator Version	
	76613-22	Dual Automatic Applicator Version	
19	LTST5000	Control Unit Test Assembly	
20	77653-00	Pressure Switch, 78398-0X Only	3PS

Recommended Spare Parts for 9040 Cascade Control Unit for REA70, REA90, and REM Applicators (Models 76580-1XXXX, -2XXXX, -6XXXX, -7XXXX)

Description	Part Number	No. of Applicators				Notes
		1-2	3-4	5-6	7-8	
PC Board Assembly, REA Applicator	76893-01	1	1	1	2	For 76580-1XXXX
PC Board Assembly, REM Applicator	76892-02	1	1	1	2	For 76580-2XXXX
PC Board Assembly, REA90 Applicator	76892-06	1	1	1	2	Waterborne, for 76580-6XXXX
PC Board Assembly, REA90 Applicator	76892-07	1	1	1	2	Solvent, for 76580-7XXXX
Fuse, PC Board	LSME0082-04	2	4	6	8	
Fuse, Front Panel	72771-06	2	4	6	8	
Tester	LTST5000-00	1	1	1	1	For testing control unit and cable.

Recommended Spare Parts for 9040 Cascade Control Unit for REA70, REA90, REA9000, and REM Automatic Applicators (Models 76580-3XXXX, -4XXXX, -8XXXX, -9XXXX)

Description	Part Number	No. of Applicators				Notes
		1-2	3-4	5-6	7-8	
PC Board Assembly, REA70 Automatic	76892-03	1	1	1	2	For 76580-3XXXX
PC Board Assembly, REM Automatic	76892-04	1	1	1	2	For 76580-4XXXX
PC Board Assembly, REA9000 Automatic	76892-05	1	1	1	2	For 76580-5XXXX
PC Board Assembly, REA90A Solventborne	76892-08	1	1	1	2	For 76580-8XXXX
PC Board Assembly, REA90A	76892-09	1	1	1	2	Solvent, for 76580-9XXXX
PC Board Assembly, Triple Setpoint	76031-15	1	1	1	2	For 76580-8XXXX
PC Board Assembly, Analog Input	76031-16	1	1	1	2	For 76580-9XXXX
PC Board Assembly, Analog Input	76031-17	1	1	1	2	For 76580-4XXXX
PC Board Assembly, Analog Input	76031-18	1	1	1	2	For 76580-5XXXX
Fuse, PC Board	LSME0082-04	2	4	6	8	
Fuse, Front Panel	72771-06	2	4	6	8	
Tester	LTST5000-00	1	1	1	1	For testing control unit and cable.

WARRANTY POLICIES

LIMITED WARRANTY

ITW Ransburg will replace or repair without charge any part and/or equipment that falls within the specified time (see below) because of faulty workmanship or material, provided that the equipment has been used and maintained in accordance with ITW Ransburg's written safety and operating instructions, and has been used under normal operating conditions. Normal wear items are excluded.

THE USE OF OTHER THAN ITW RANSBURG APPROVED PARTS, VOID ALL WARRANTIES.

SPARE PARTS: One hundred and eighty (180) days from date of purchase, except for rebuilt parts (any part number ending in "R") for which the warranty period is ninety (90) days.

EQUIPMENT: When purchased as a complete unit, (i.e., guns, power supplies, control units, etc.), is one (1) year from date of purchase. **WRAPPING THE APPLICATOR IN PLASTIC, ASSOCIATED VALVES AND TUBING, AND SUPPORTING HARDWARE IN PLASTIC, SHRINK-WRAP, OR ANY OTHER NON-APPROVED COVERING, WILL VOID THIS WARRANTY.**



ITW RANSBURG'S ONLY OBLIGATION UNDER THIS WARRANTY IS TO REPLACE PARTS THAT HAVE FAILED BECAUSE OF FAULTY WORKMANSHIP OR MATERIALS. THERE ARE NO IMPLIED WARRANTIES NOR WARRANTIES OF EITHER MERCHANTABILITY OR FITNESS FOR A PARTICULAR PURPOSE. ITW RANSBURG ASSUMES NO LIABILITY FOR INJURY, DAMAGE TO PROPERTY OR FOR CONSEQUENTIAL DAMAGES FOR LOSS OF GOODWILL OR PRODUCTION OR INCOME, WHICH RESULT FROM USE OR MISUSE OF THE EQUIPMENT BY PURCHASER OR OTHERS.

EXCLUSIONS:

If, in ITW Ransburg's opinion the warranty item in question, or other items damaged by this part was improperly installed, operated or maintained, ITW Ransburg will assume no responsibility for repair or replacement of the item or items. The purchaser, therefore will assume all responsibility for any cost of repair or replacement and service related costs if applicable.

MANUAL CHANGE SUMMARY

This manual was published to replace Service Manual **CP-97-04.2** to make the following changes:

1. Added “  ” to the “Front Cover”.
2. Added “Atex” section and “Labels 42562 and 79318” to the “Atex” section.

Service Manual Price: €25.00 (Euro)
\$30.00 (U.S.)

Manufacturing

1910 North Wayne Street
Angola, Indiana 46703-9100
Telephone: 260/665-8800
Fax: 260/665-8516

Technical/Service Assistance

Automotive Assembly and Tier I
Industrial Systems
Ransburg Guns
www.itwransburg.com

Telephone: 800/ 626-3565 Fax: 419/ 470-2040
Telephone: 800/ 233-3366 Fax: 419/ 470-2071
Telephone: 800/ 233-3366 Fax: 419/ 470-2071

Technical Support Representative will direct you to the appropriate telephone number for ordering Spare Parts.

